

INSTALLATION INSTRUCTIONS: 2015+ COLORADO/CANYON RAIL CAP

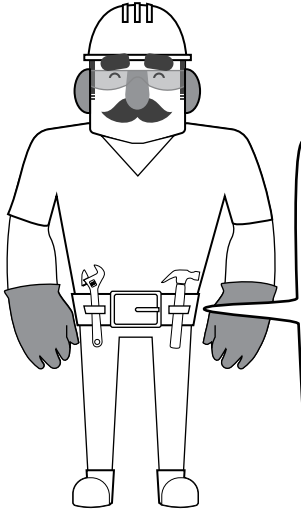

TOOLS NEEDED:

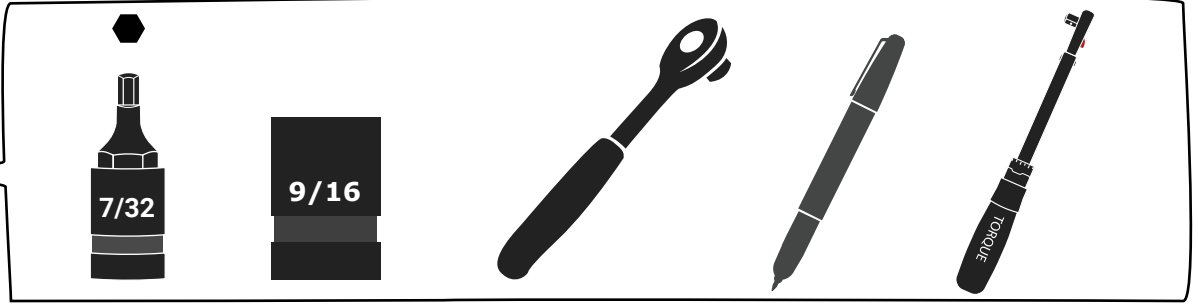

CAUTION:

This equipment is designed to be professionally installed by an approved up-fitter. Always wear ear and eye protection and exercise caution when installing Westcan products.

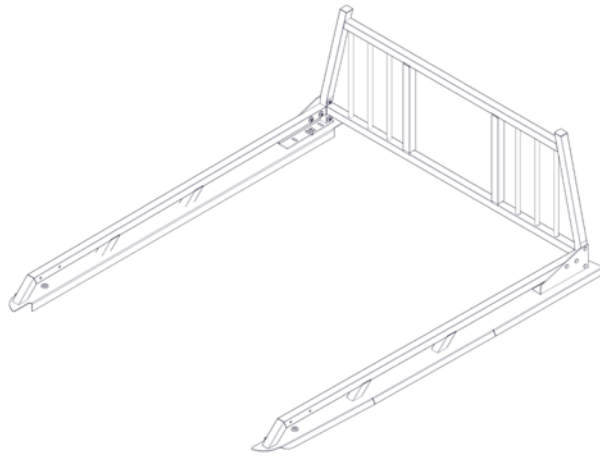

SHORT BOX

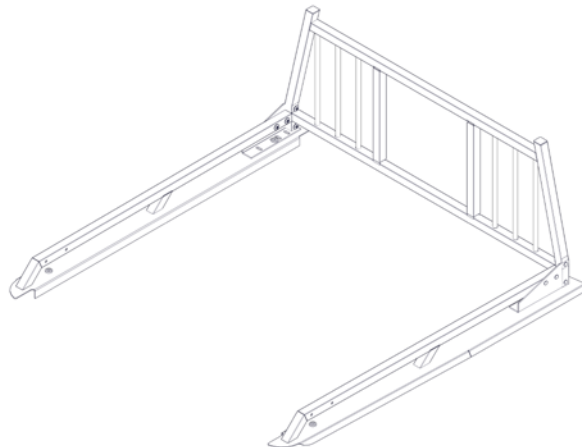

EXTRA SHORT BOX

PREPARATION:

1. Ensure all parts are present and accounted for before installation. **Begin the installation of your cabguard before your rail caps.** Plan the location of your installation ahead of time and make sure your installation location does not impede any other components you are installing or damage the safety and functionality of your vehicle.
2. Exercise extreme diligence when drilling holes into a motor vehicle. Increasing complexity and model year changes can alter the location of fuel, hydraulic and electrical lines. Please visually inspect all locations prior to drilling.
3. Re-Torque the 3/8" x 1-3/4" Stainless Steel Countersink Bolt every 3 month.

1.

EXTRA SHORT BOX AND SHORT BOX



X 2

2. REQUIRED FOR EXTRA SHORT, SHORT AND LONG BOX REAR STAKE POCKET

3/8" x 1 1/4" Stainless Steel Hex Bolt

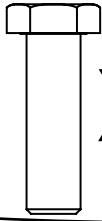

X 2

3/8" Stainless Steel Lock Washer



X 2

3/8" Stainless Steel Flat Washer



X 2



X 2

2.1 REMOVE TAILLIGHT HOUSING FOLLOWING VEHICLE MANUFACTURERS GUIDELINES.

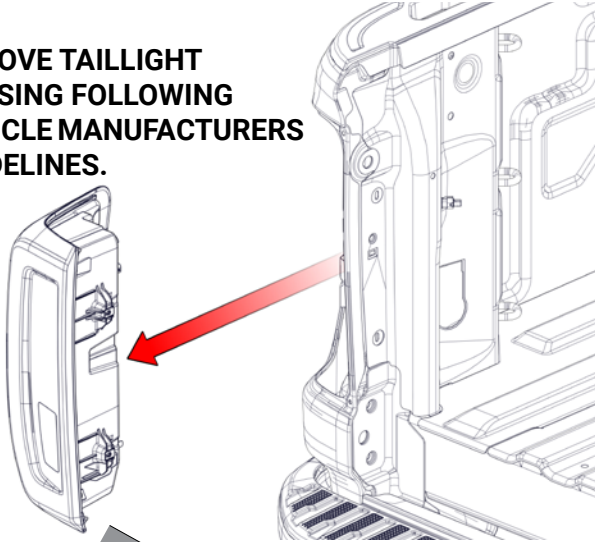

2.4

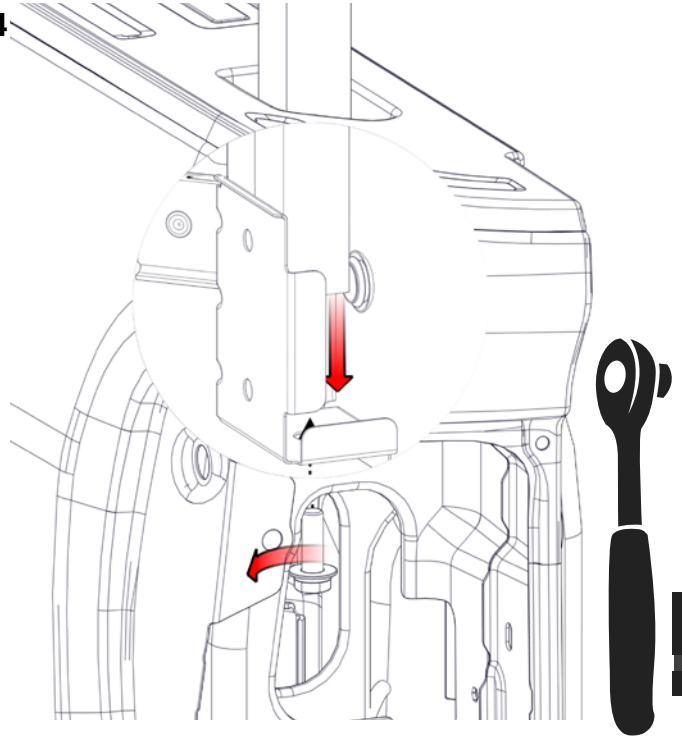

9/16

2.2

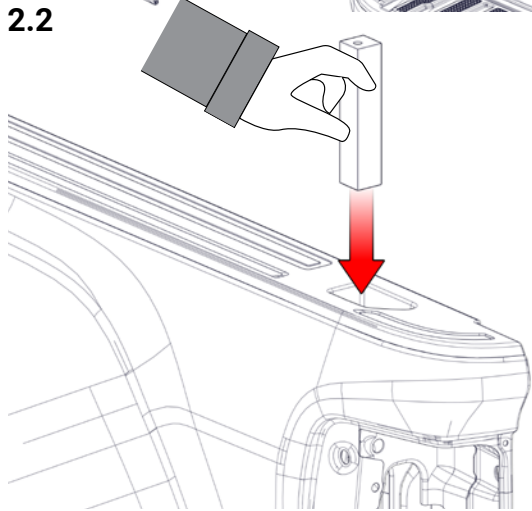

2.5

2.3

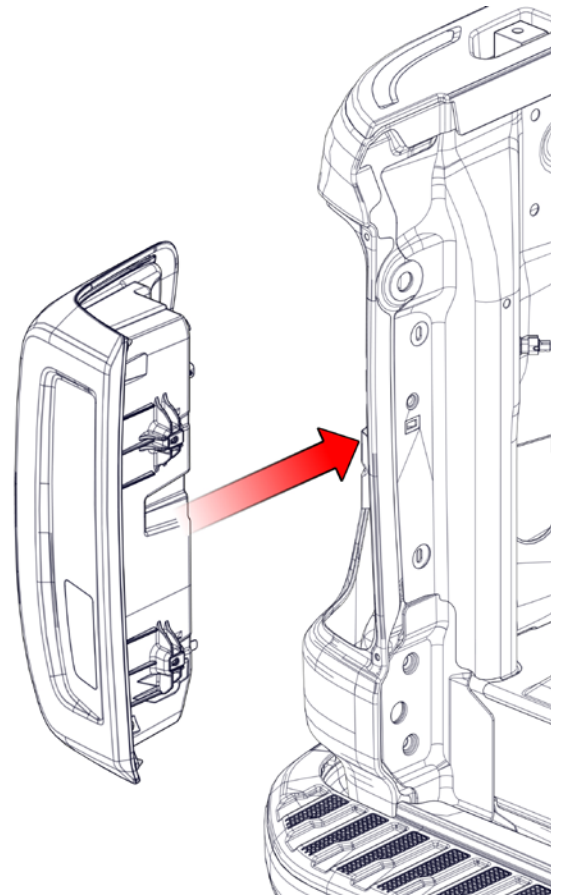
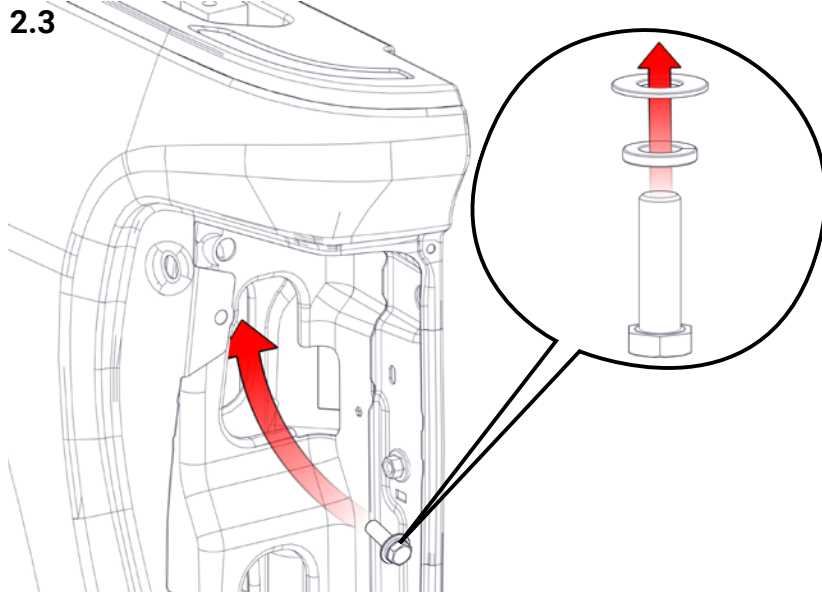

3.

EXTRA SHORT BOX AND SHORT BOX

3/8 X 1 3/4 Stainless Steel Counter Sink Bolt

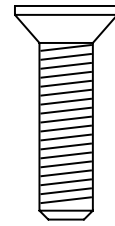
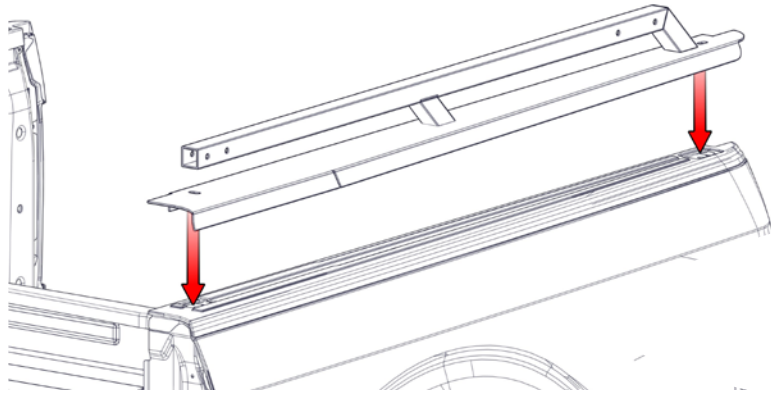

X 2

3/8" Stainless Steel Finishing Washer

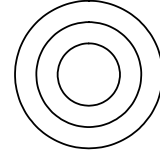

X 2

Anti-Sieze Lubricant

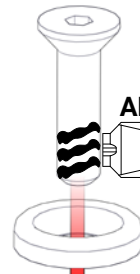
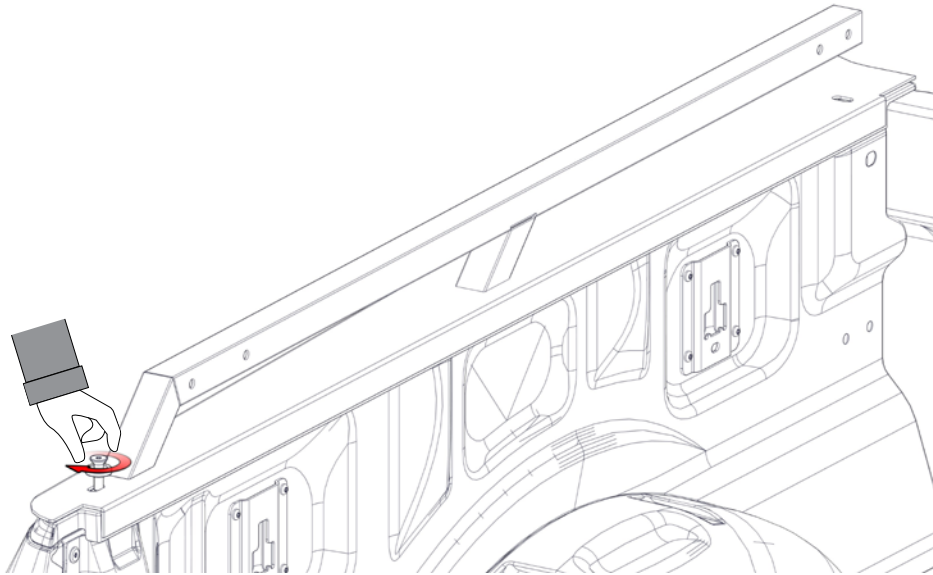
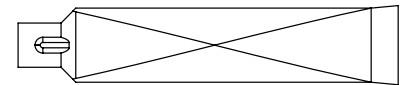

APPLY ANTI-SIEZE

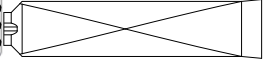

**=90 IN-LBF
=7.5 FT-LBF**

**IF INSTALLING WITH A CABGUARD,
TORQUE DOWN WHEN THE CABGUARD
INSTALL IS COMPLETE.**

