

INSTALLATION INSTRUCTIONS: 2015-2020 FORD F-150 OVER CANOPY RACK BRACKET GUIDE

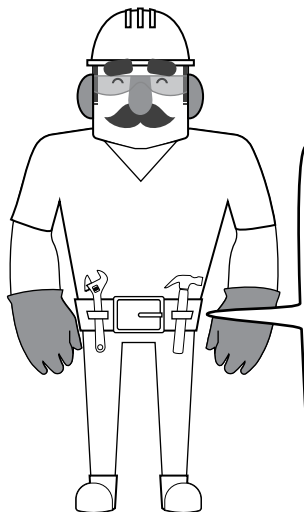

TOOLS NEEDED:

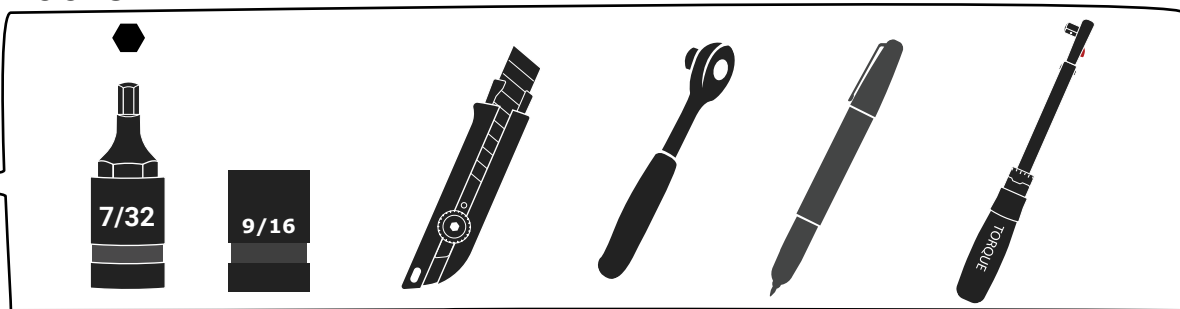

CAUTION:

This equipment is designed to be professionally installed by an approved up-fitter. Always wear ear and eye protection and exercise caution when installing Westcan products.

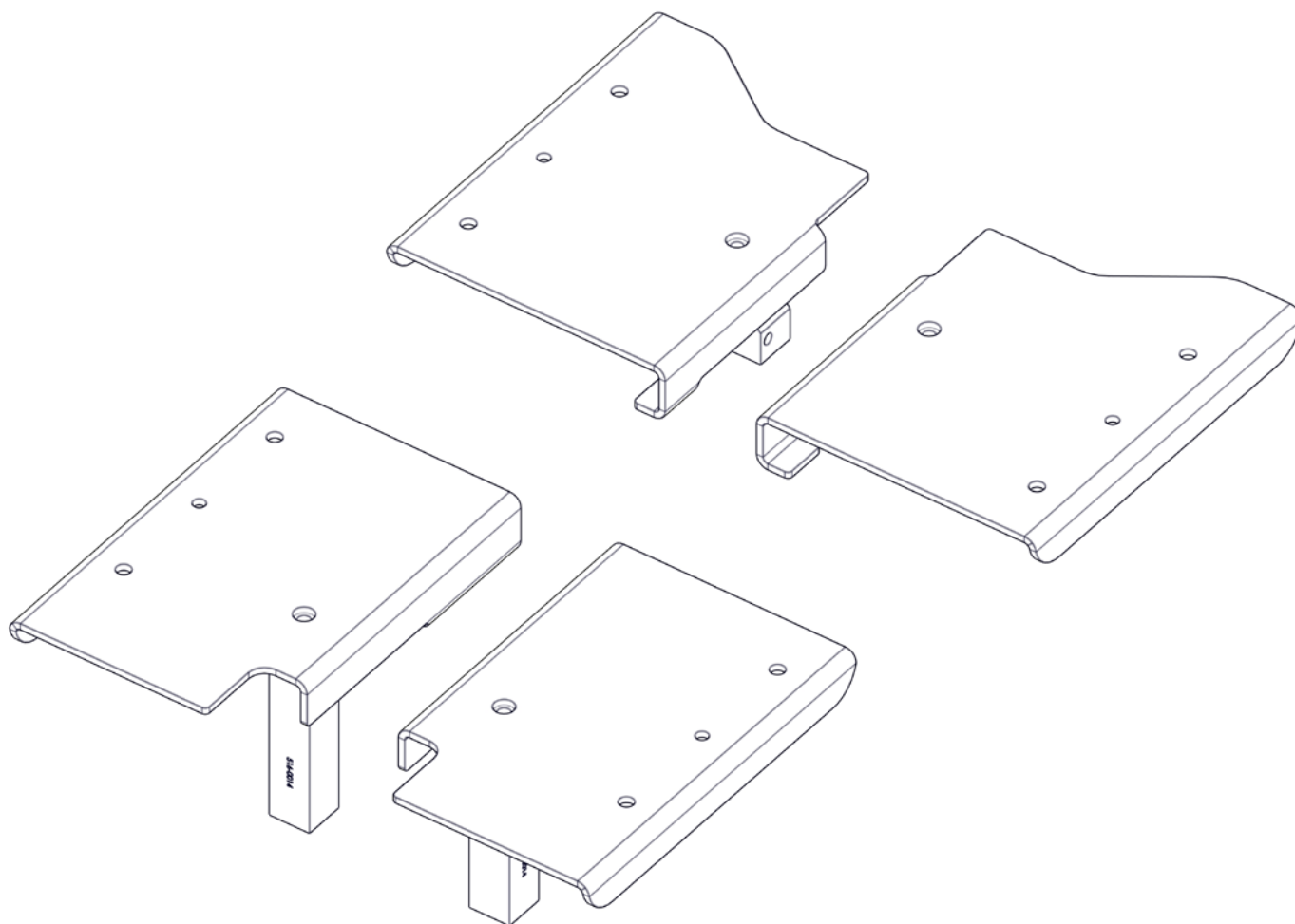

PREPARATION:

1. Ensure all parts are present and accounted for before installation. **Install the over canopy rack base plates on you vehicle before starting the assembly of your over canopy rack.** Plan the location of your installation ahead of time and make sure your installation location does not impede any other components you are installing or damage the safety and functionality of your vehicle.
2. Exercise extreme diligence when drilling holes into a motor vehicle. Increasing complexity and model year changes can alter the location of fuel, hydraulic and electrical lines. Please visually inspect all locations prior to drilling.
3. Re-Torque the 3/8" x 1-3/4" Stainless Steel Countersink Bolt every 3 month.
4. Images used illustrate a typical installation. The parts in your specific installation may appear different but the installation procedure remains the same.
5. If equipped, remove the truck canopy prior to installation. You may be required to relief cut the canopy skirt around the installation brackets for proper canopy fit. If desired, install canopy seal tape on the bottom of the cap to help keep rain or water out of the truck box (not supplied). Remember to also install extra canopy seal along the front of the canopy because it will sit off of the box of the truck Once the cap is between the canopy and the truck box.

BOX CAP PREPARATION:

Some truck box lengths require the plastic truck box caps to be cut to expose the stake pocket cutout. Cut out around the relief in the plastic box cap. Exercise caution when cutting caps to avoid injury.

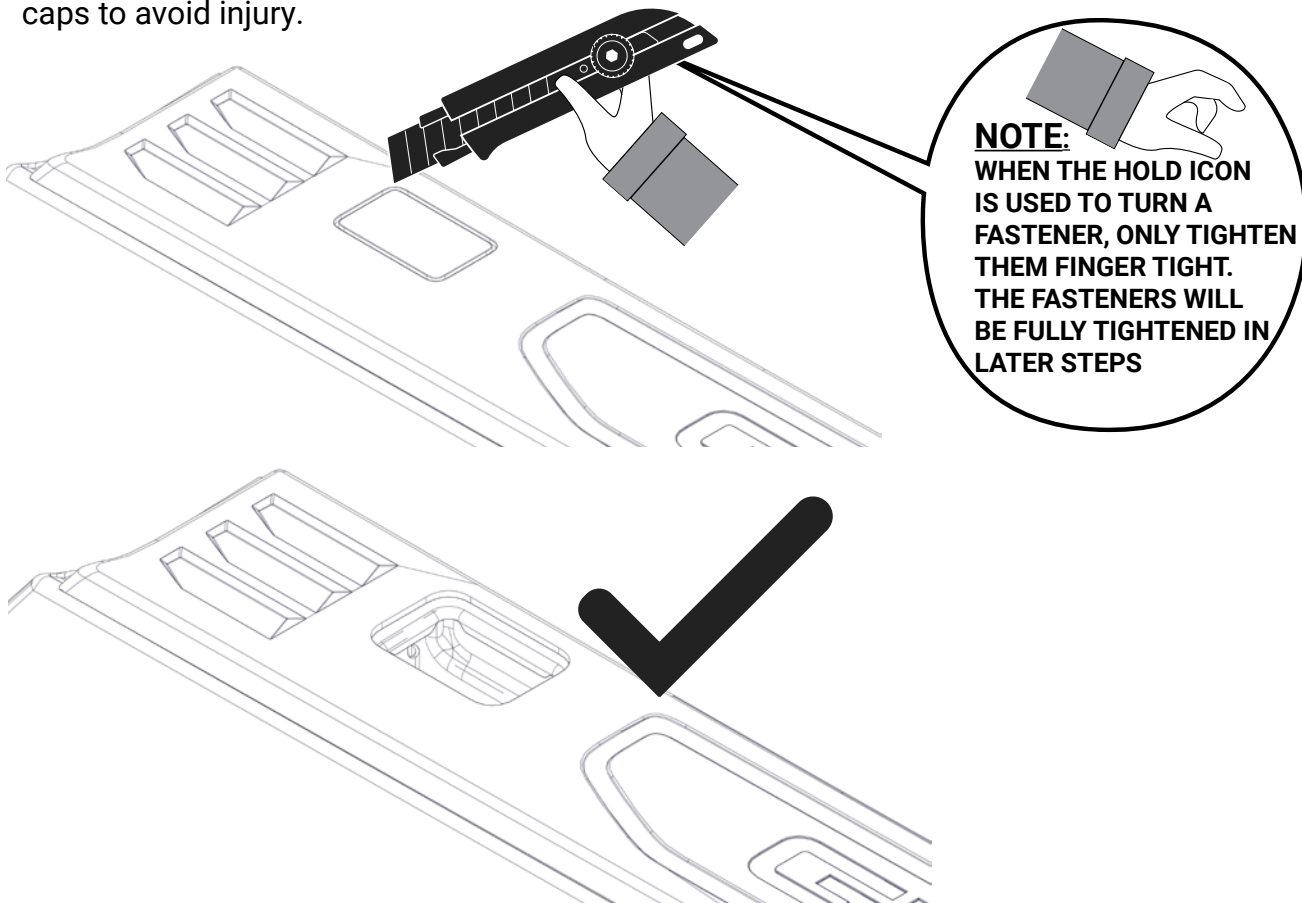

1. CUT THE PLASTIC BOX CAP TO EXPOSE THE FRONT STAKE POCKET HOLES ON THE EXTRA SHORT BOX. REMOVE THE PLASTIC STAKE POCKET COVERING CAPS FOR THE SHORT AND LONG BOX VEHICLES.

2. FRONT STAKE POCKET INSERTS

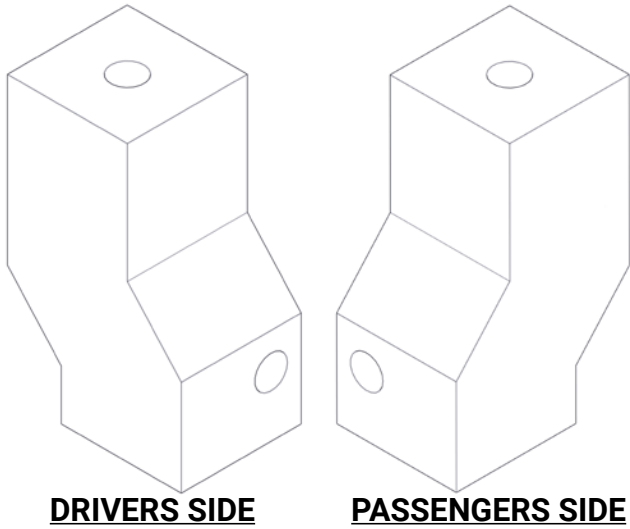

OCR BASE PLATES

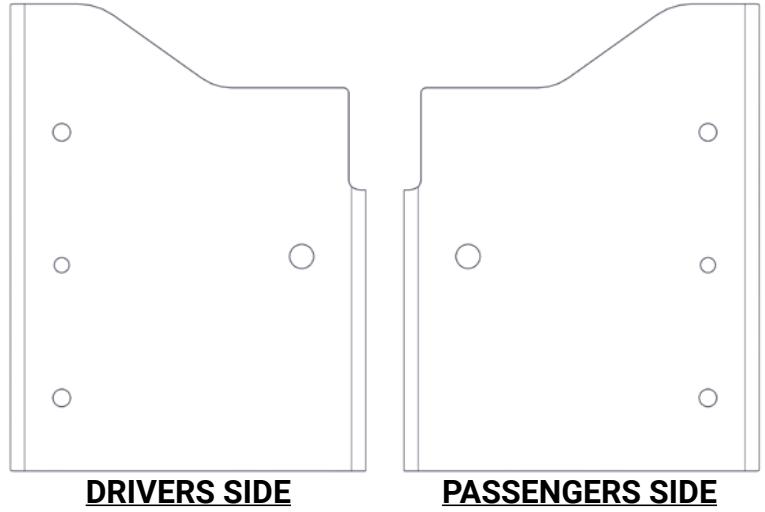

REAR STAKE POCKET INSERTS

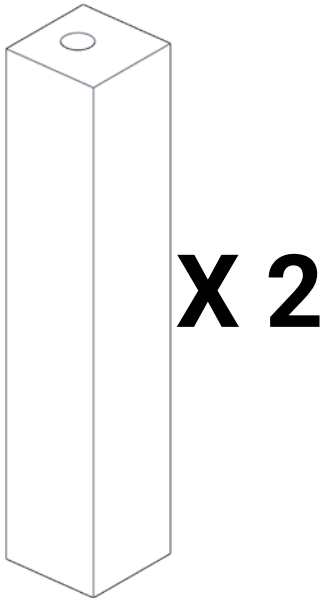

OCR BASE PLATES

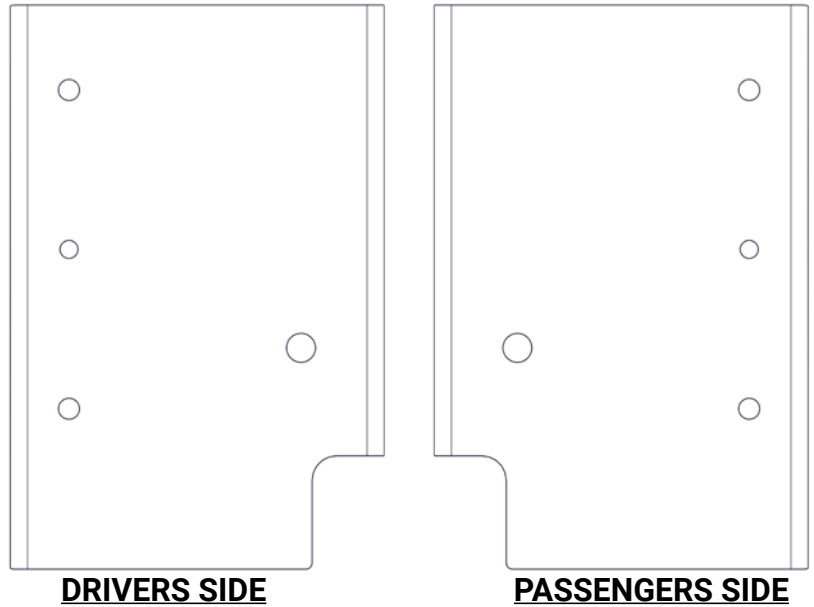

3.

REQUIRED FOR FRONT STAKE POCKETS

3/8 X 1 1/2 Stainless Steel Counter Sink Bolt

3/8" Stainless Steel Fender Washer

3/8" Stainless Steel Finishing Washer

Front Stake Pocket Inserts

3.1

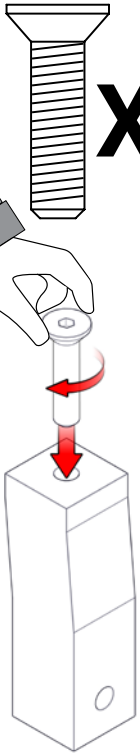

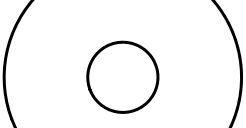
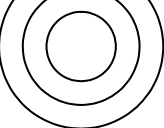
X 4  **X 2**  **X 2**

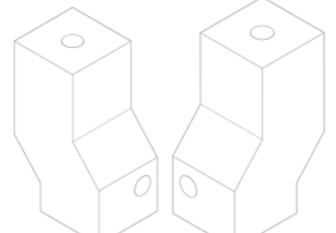

Drivers Side

Passengers Side

3.4

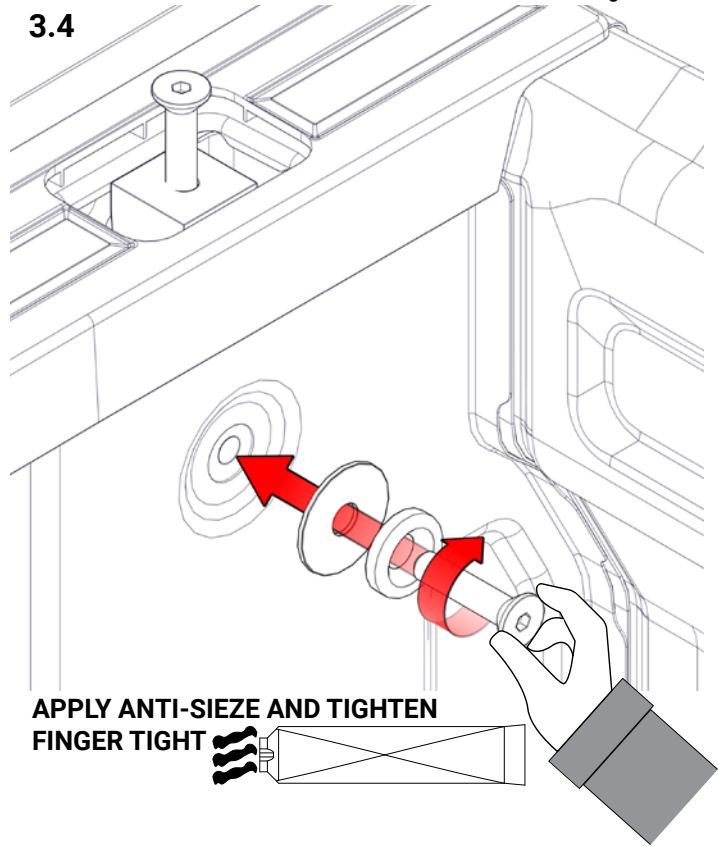

APPLY ANTI-SIEZE AND TIGHTEN FINGER TIGHT

3.3

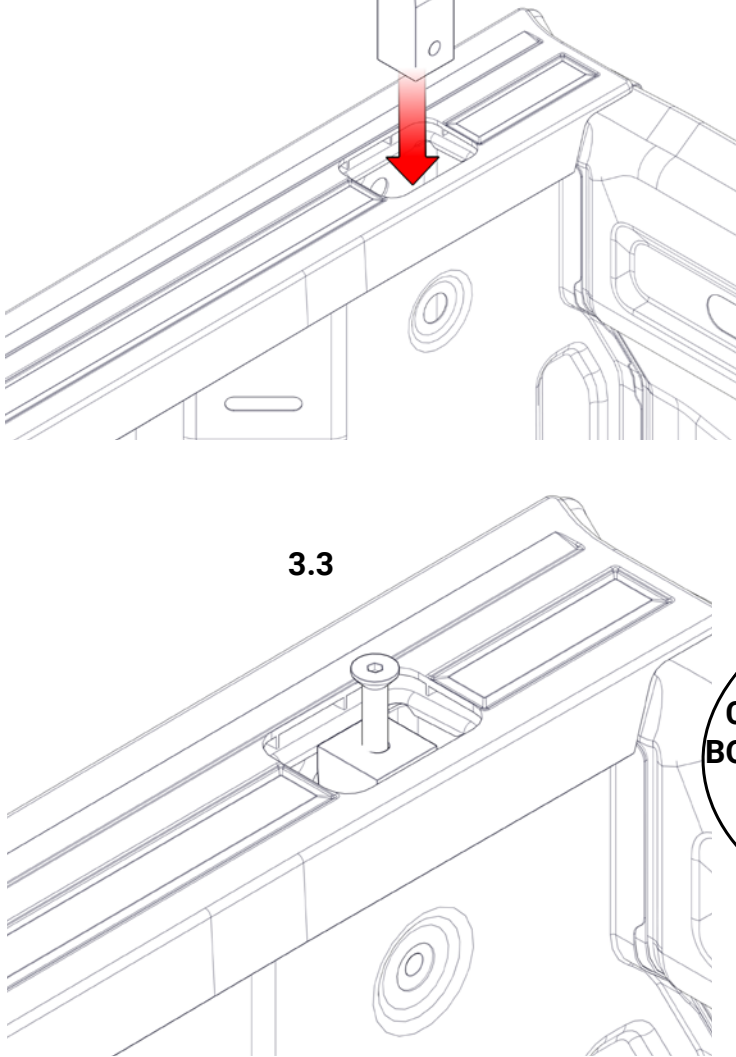

3.5

REMOVE COUNTER SINK BOLT AND RETAIN. REPEAT FOR PASSENGER SIDE

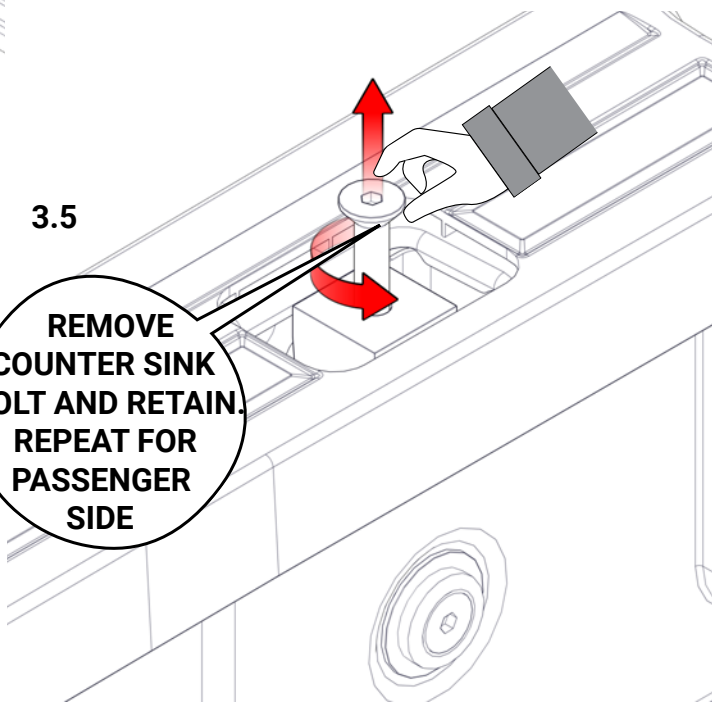

REQUIRED FOR REAR STAKE POCKETS

4. 3/8" x 1 1/4" Stainless Steel Hex Bolt

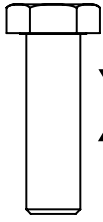

X 2

3/8" Stainless Steel Lock Washer

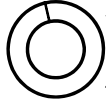

X 2

3/8" Stainless Steel Flat Washer

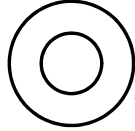

X 2

Rear Stake Pocket Inserts



X 2

4.1 REMOVE TAILLIGHT HOUSING FOLLOWING VEHICLE MANUFACTURERS GUIDELINES.

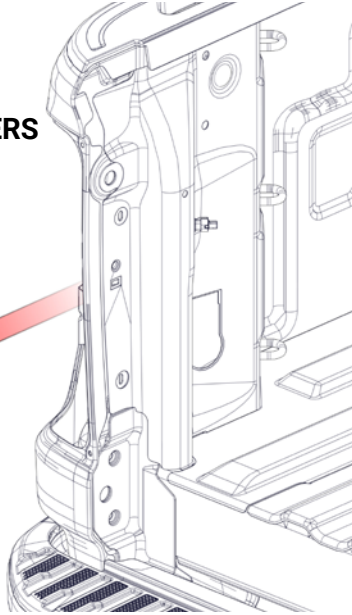
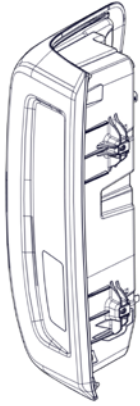

4.3

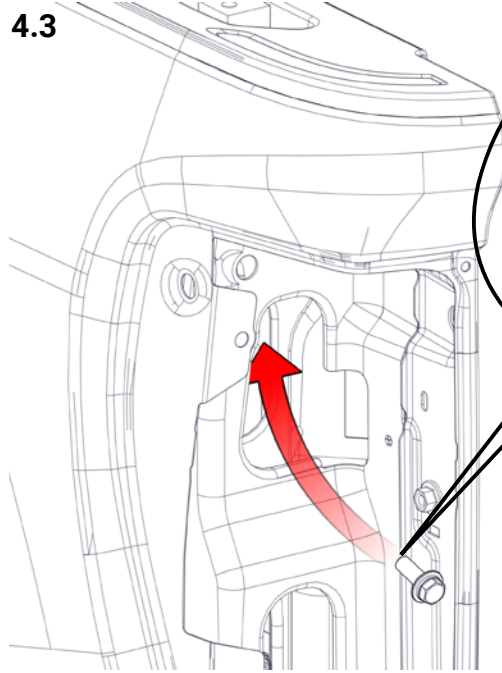

4.2

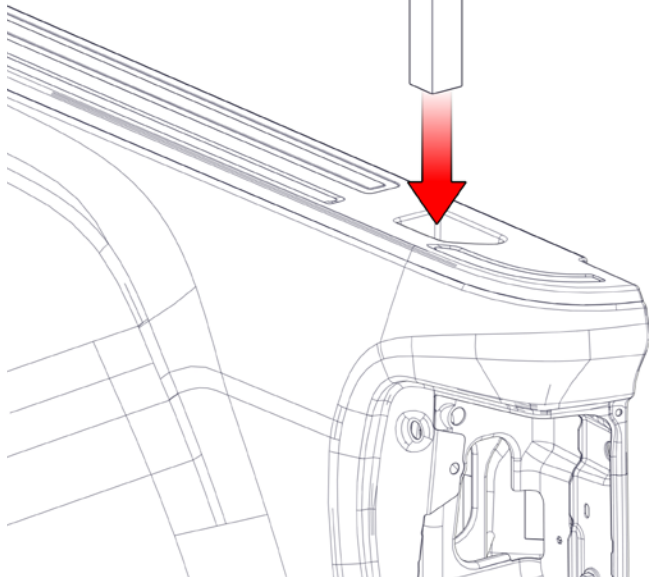
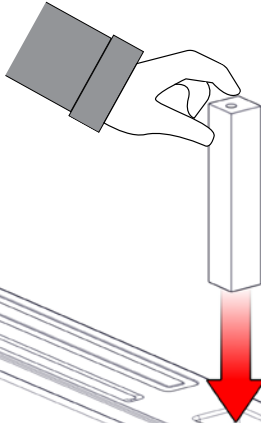

4.4

APPLY ANTI-SIEZE AND TIGHTEN FINGER TIGHT. REPEAT FOR PASSENGER SIDE

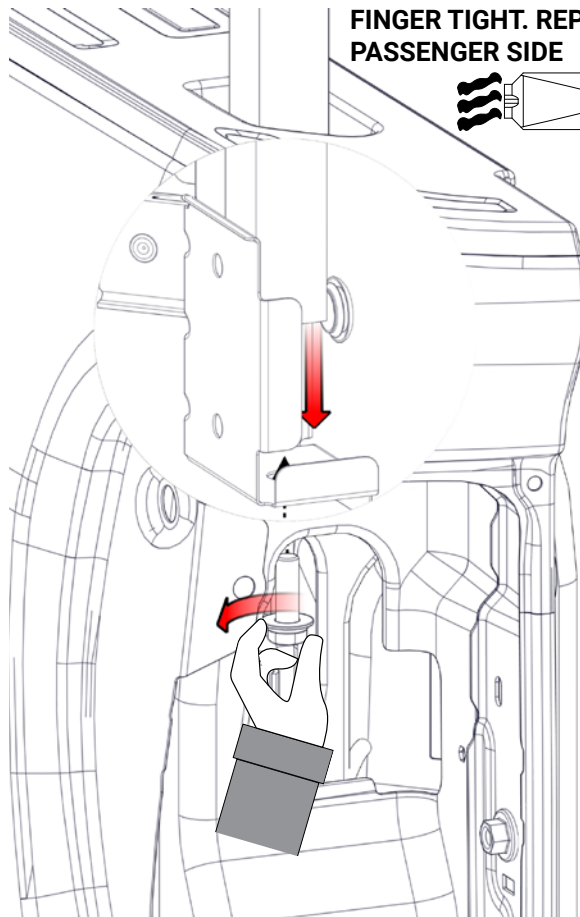

5.

FRONT OCR BASE PLATE INSTALLATION

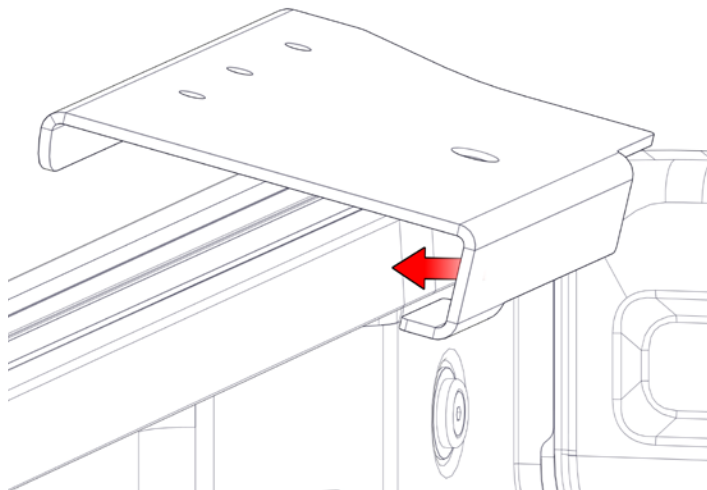
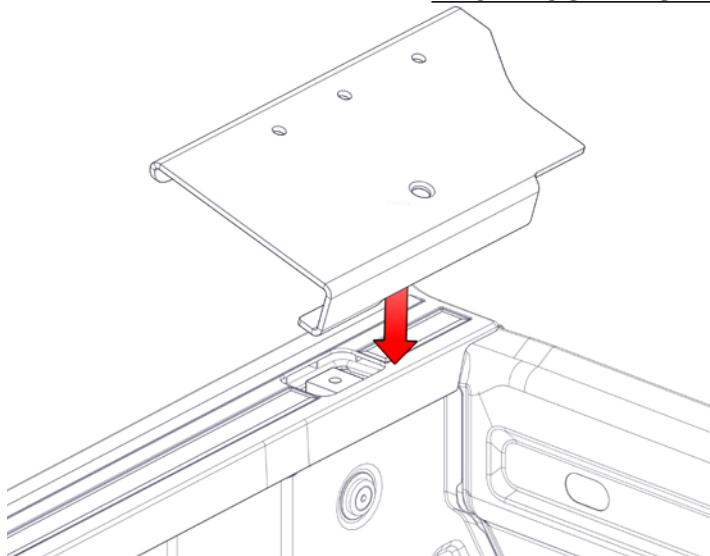

6.

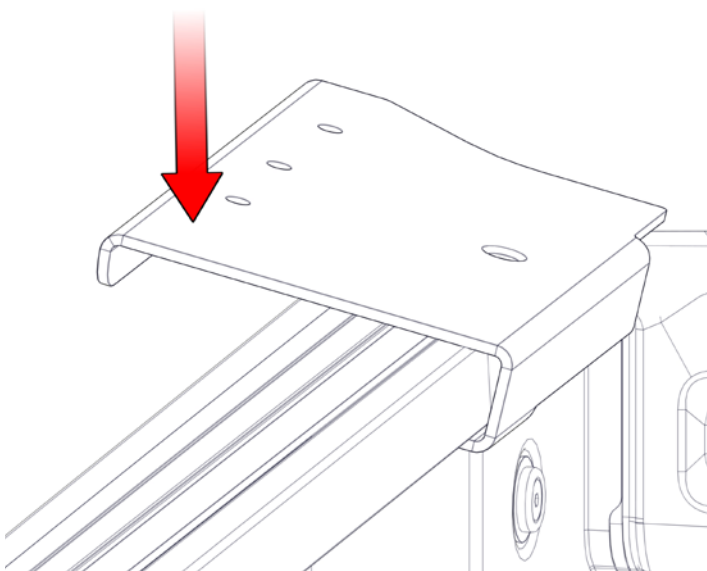
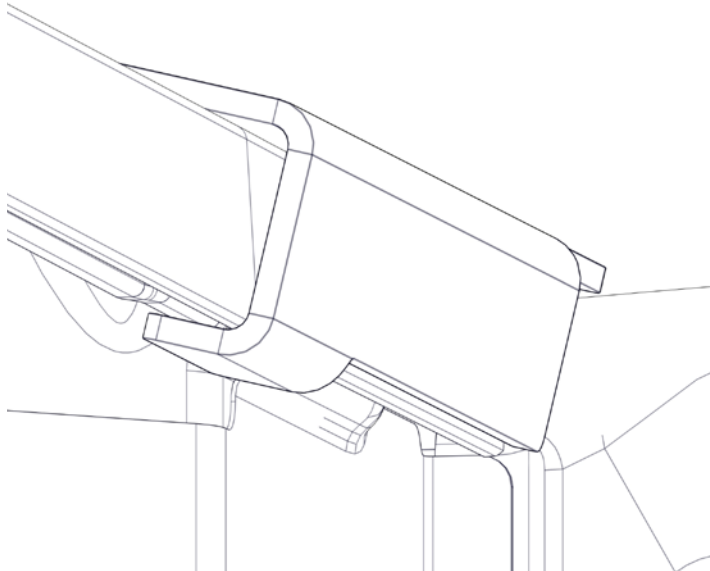

7.

3/8 X 1 1/2 Stainless Steel Counter Sink Bolt

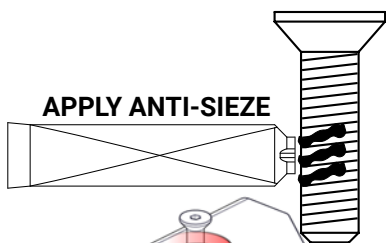

=25 FT-LBF

REPEAT STEPS 5-7 FOR PASSENGER SIDE OCR BASEPLATE

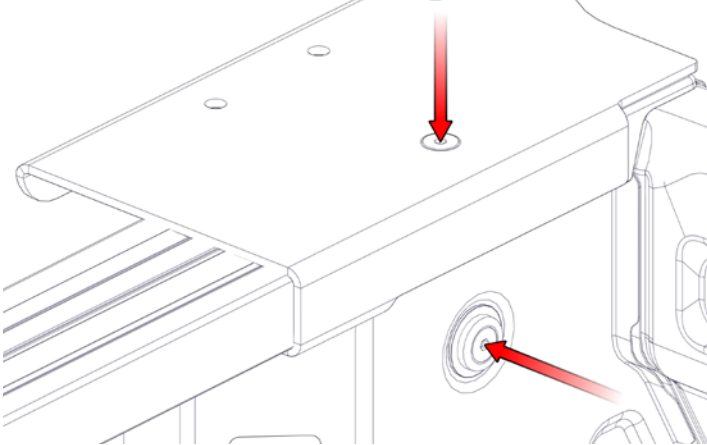
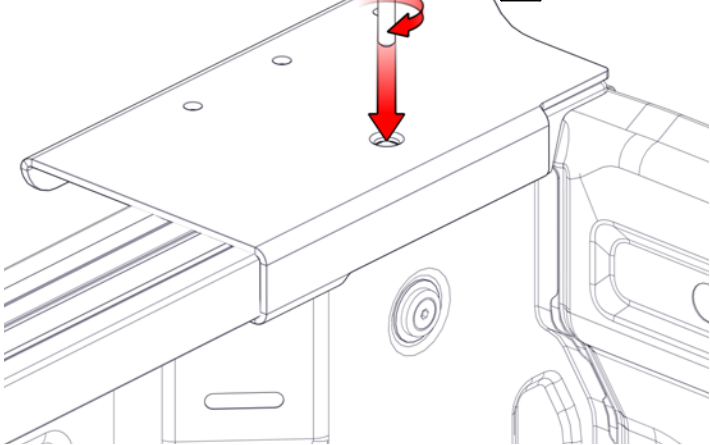

8.

REAR OCR BASE PLATE INSTALLATION

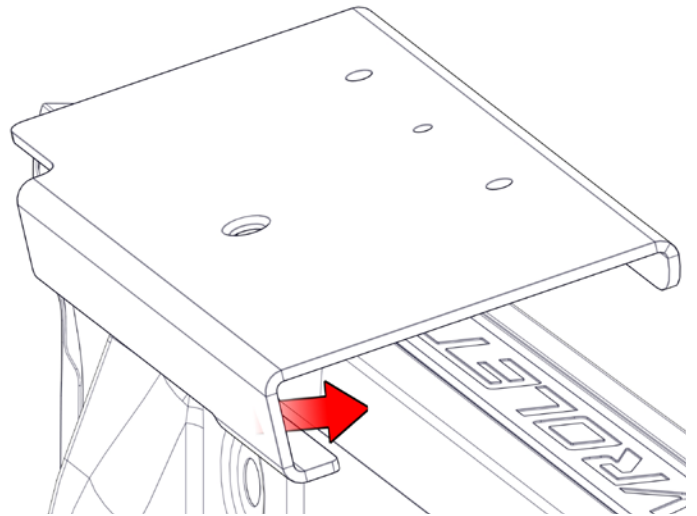
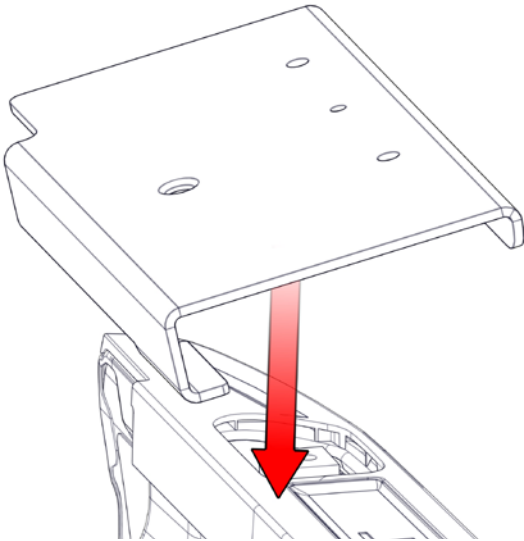

9.

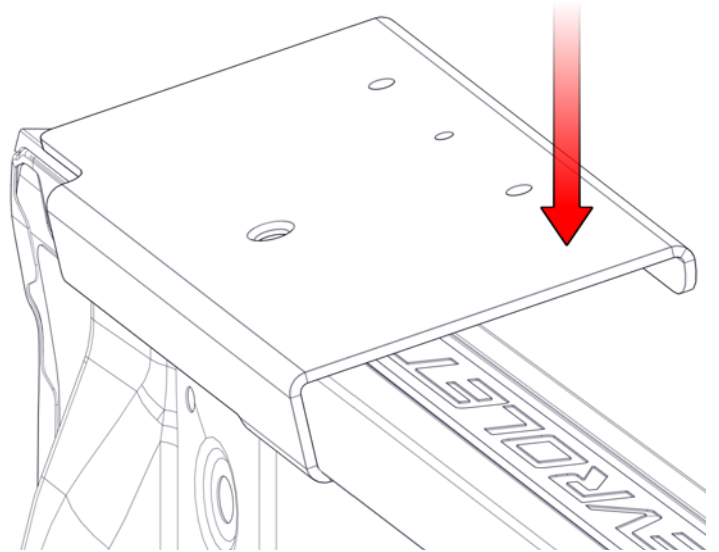
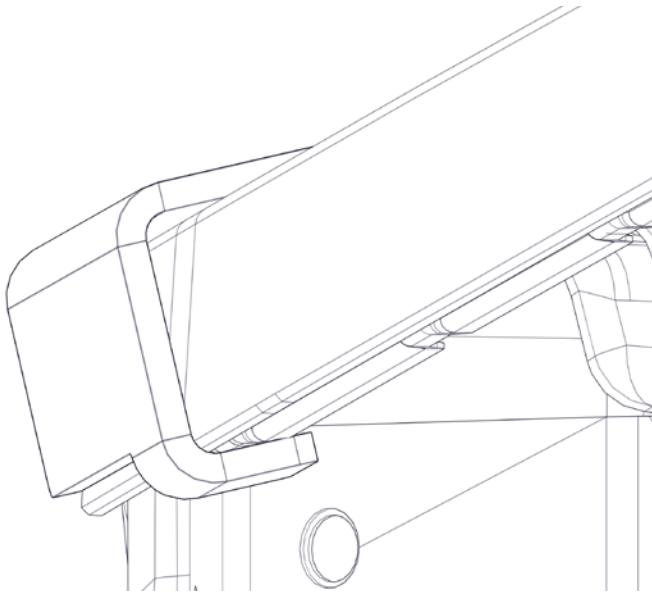

10.

3/8 X 1 1/2 Stainless Steel Counter Sink Bolt

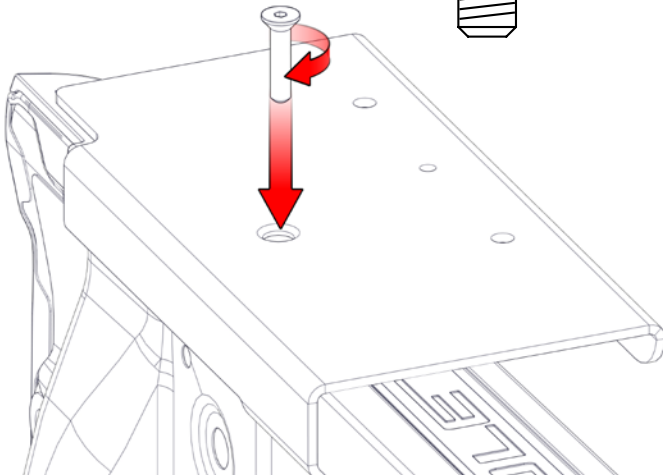
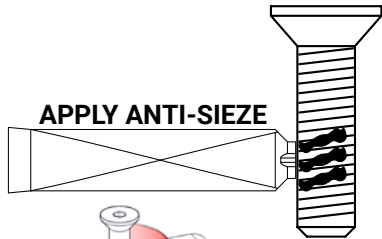

=25 FT-LBF

REPEAT STEPS 8-10 FOR PASSENGER SIDE OCR BASEPLATE

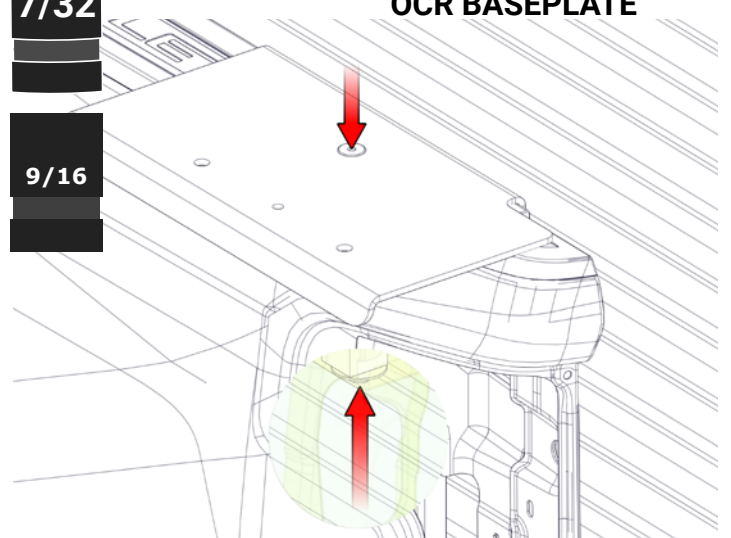

- 11. RE-INSTALL REAR DRIVERS AND PASSENGERS SIDE TAILLIGHT HOUSING FOLLOWING VEHICLE MANUFACTURERS GUIDELINES.**

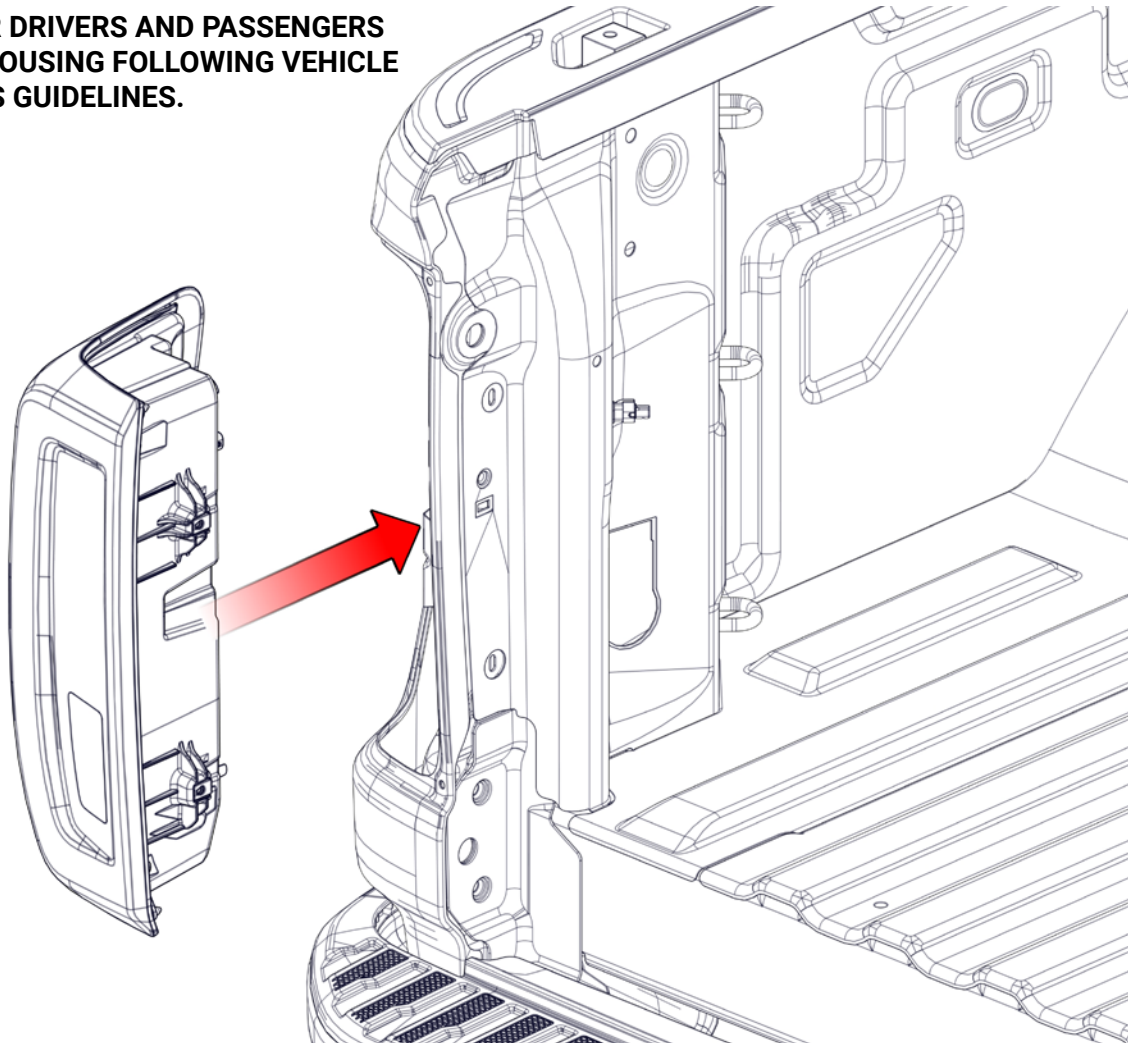

IF YOUR INSTALLATION IS OVER A TRUCK BOX CANOPY, INSTALL THE CANOPY FIRST THEN INSTALL THE RACK. YOU MAY BE REQUIRED TO RELIEF CUT THE CANOPY SKIRT AROUND THE INSTALLATION BRACKETS.

2015-2020 FORD F-150 OCR SPACING GUIDE

LONG BOX FORWARD BAR SPACING



SHORT BOX FORWARD BAR SPACING

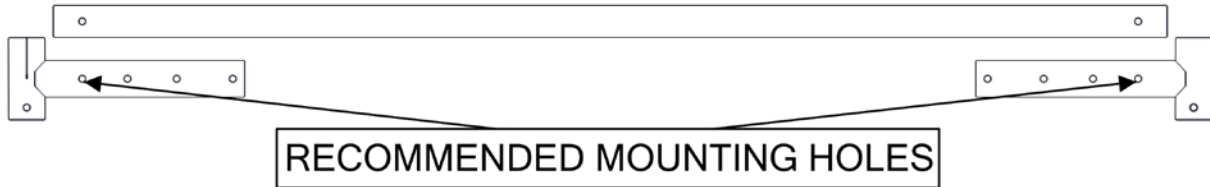

EXTRA SHORT BOX FORWARD BAR SPACING

FORWARD BAR TO BE CUT DOWN BY 12-1/16". YOU WILL BE REQUIRED TO DRILL A 7/16" HOLE 1-3/4" IN FROM THE CUT END

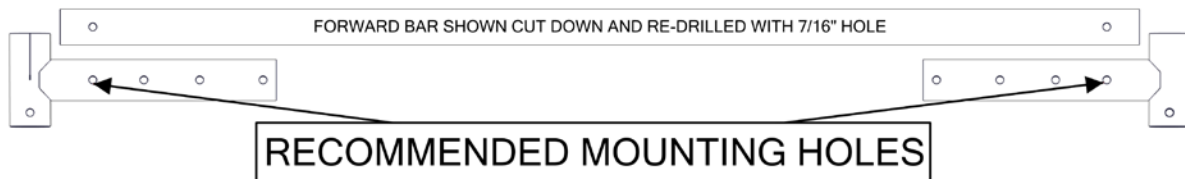

6-5/8" ABOVE CAB HEIGHT LEG MOUNTING HOLES

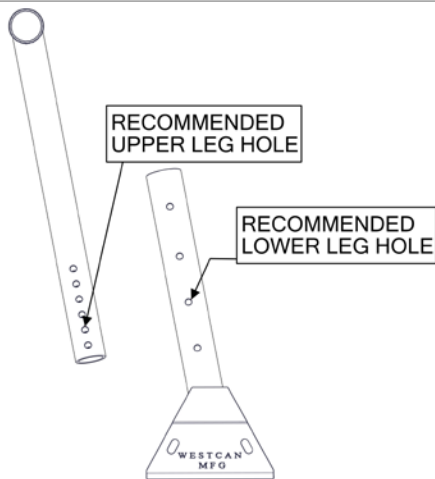

2-5/8" ABOVE CAB HEIGHT LEG MOUNTING HOLES

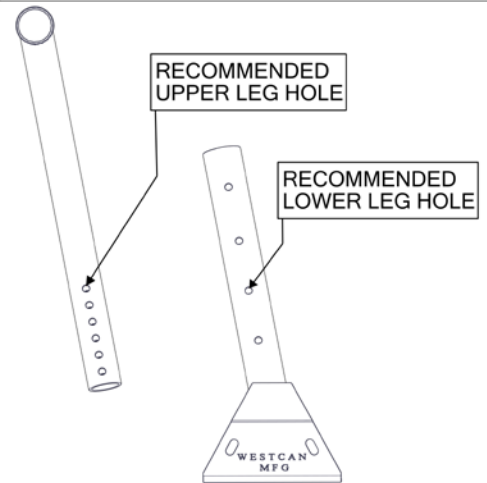

FRONT CROSS BAR RECOMMENDED HOLE FOR 2-5/8" ABOVE CAB HEIGHT



FRONT CROSS BAR RECOMMENDED HOLE FOR 6-5/8" ABOVE CAB HEIGHT



REAR CROSS BAR RECOMMENDED HOLE FOR 2-5/8" ABOVE CAB HEIGHT



REAR CROSS BAR RECOMMENDED HOLE FOR 6-5/8" ABOVE CAB HEIGHT

