

# INSTALLATION INSTRUCTIONS: SPRINTER SECOND ROW PARTITION

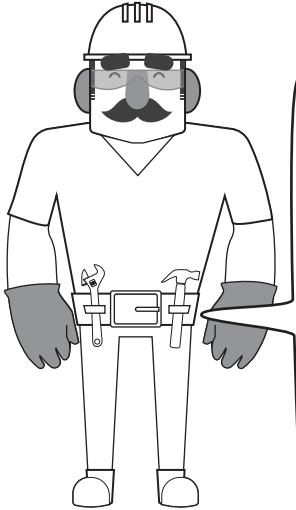

## TOOLS NEEDED:

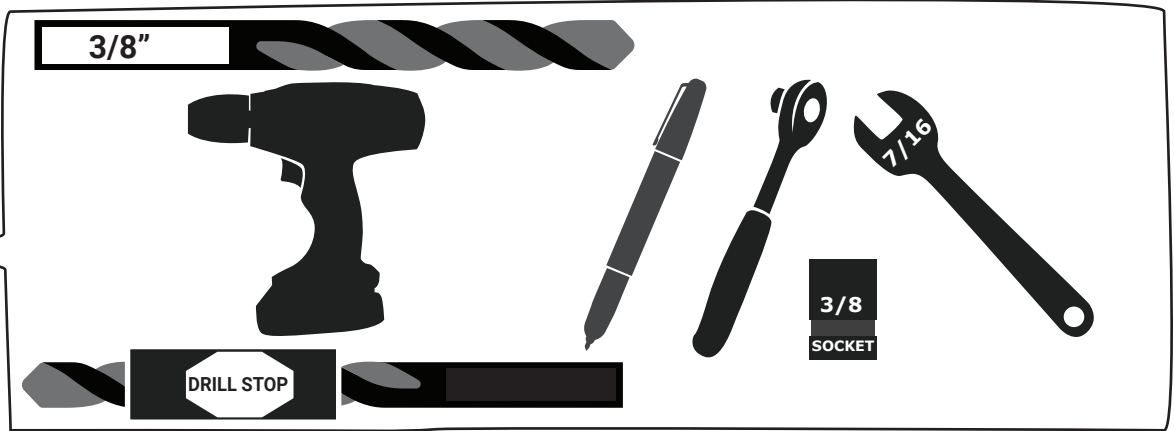

## CAUTION:



This equipment is designed to be professionally installed by an approved upfitter. Always wear the appropriate Personal Protection Equipment as outlined by your local government and exercise caution when installing Westcan Manufacturing products. Westcan Manufacturing is not responsible for any damage done to the vehicle resulting from a poorly planned and/or executed installation. Both the installer and vehicle owner accept responsibility to properly install and operate Westcan Manufacturing products.

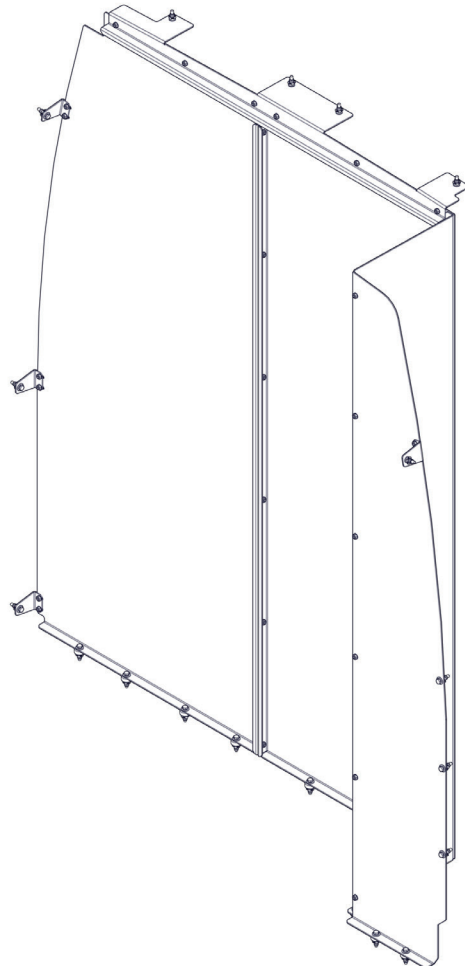

## PREPARATION:

1. Ensure all parts are present and accounted for before installation. Plan the location of your installation ahead of time and make sure your installation location does not impede any other components you are installing or damage the safety and functionality of your vehicle.
2. Install all plywood floor, ceiling and wall liners prior to installing the partition.
3. Every installation is different and can present its own unique challenges. Some hardware and interior trim may need to be altered to fit unique applications.
4. Exercise extreme diligence when drilling holes into a motor vehicle. Increasing complexity and model year changes can alter the location of fuel, hydraulic and electrical lines. Please visually inspect all locations prior to drilling.

**CAUTION:** 

5. Use drill stops whenever drilling a hole in your vehicle. Set the drill stop depth to the minimum effective depth required to drill the hole.

## INSERT NUT INSTALLATION:

Insert Nut For Up To 1/4" Thick Material.

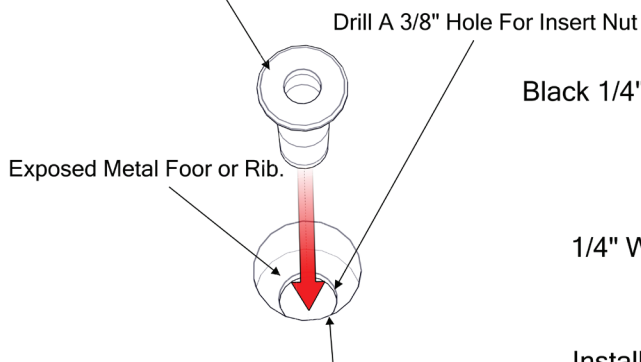

**1" Counter-bore Through Plywood Floor or Rubber Floor Mat and Install 1" Aluminum Spacers.**

**REFER BACK WHEN INSERT NUT IS USED.**



**- Torque to 25 ft-lb to fully collapse the insert nut.**

Black 1/4" X 2-1/4" Install Bolt

1/4" Washer

Install Tool

Insert Nut

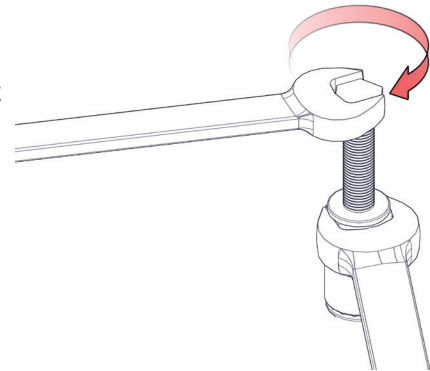

1.

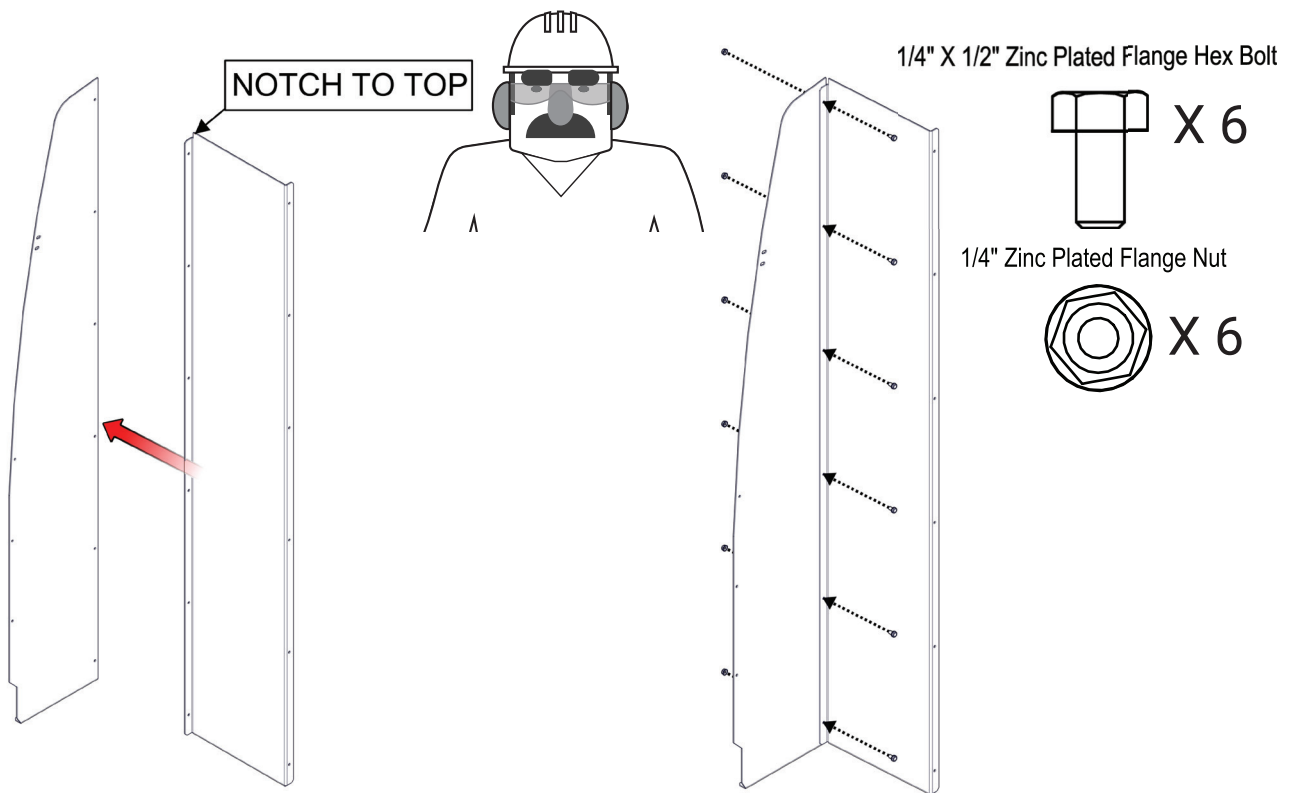

2.

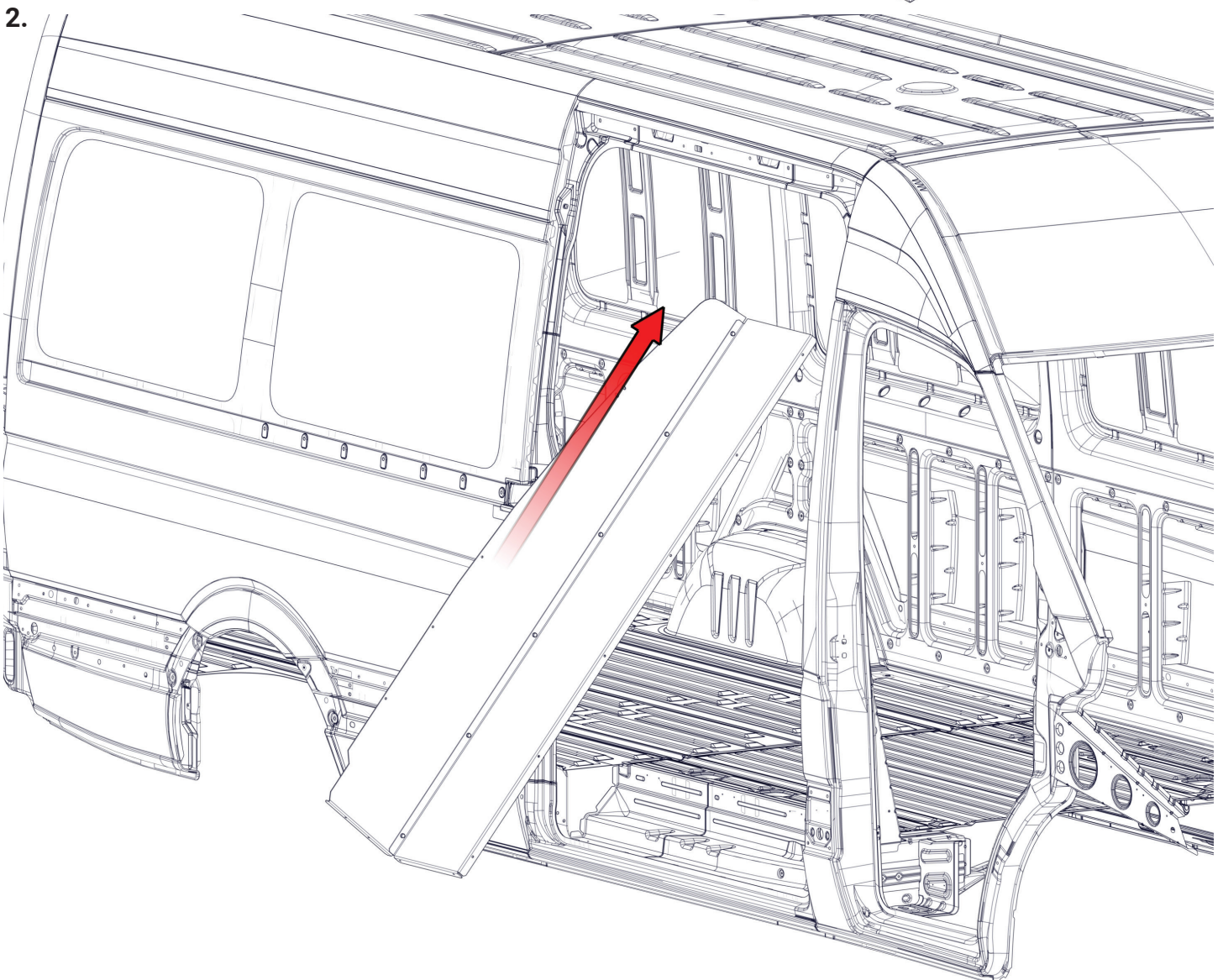

3.

3.

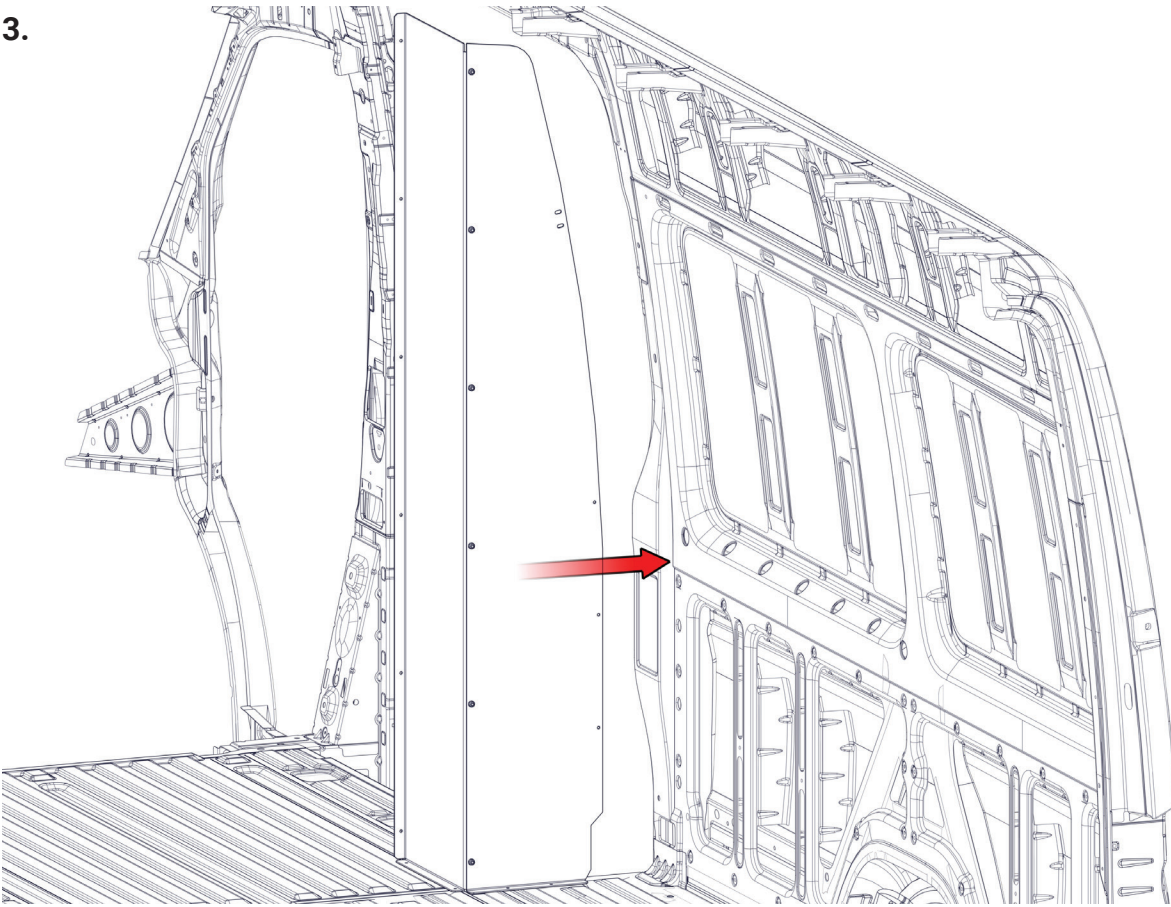

4.

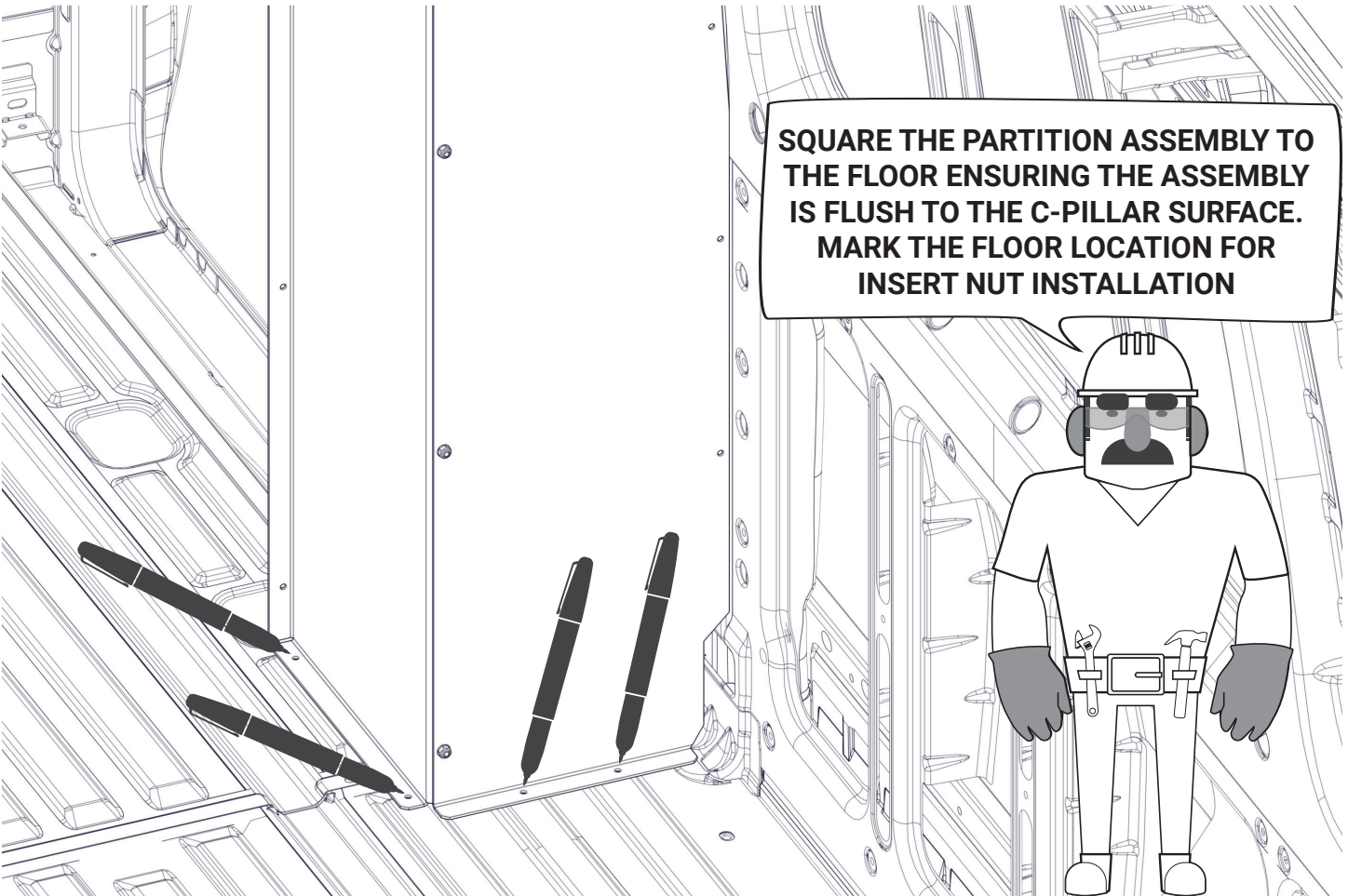

4.

5.

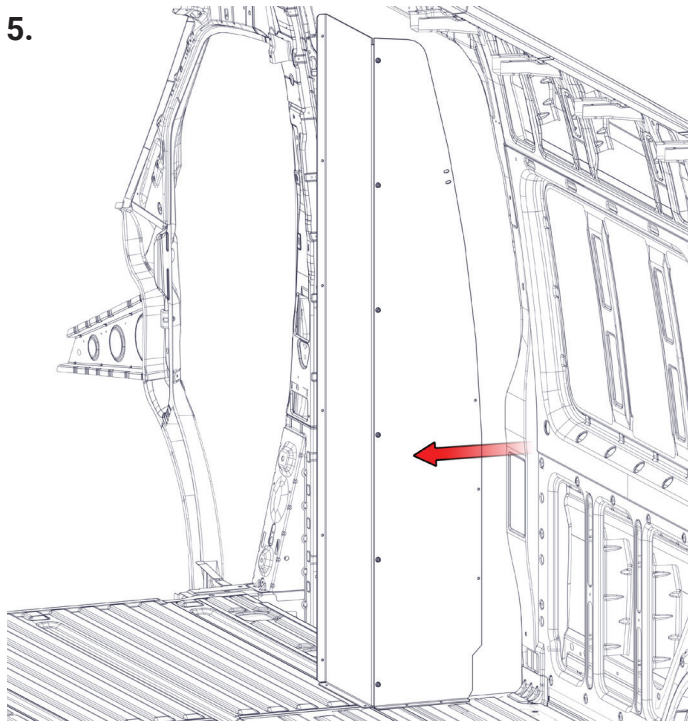

REMOVE ASSEMBLY AND DRILL MARKED LOCATIONS WITH A 3/8" DRILL BIT FOR INSERT NUTS.

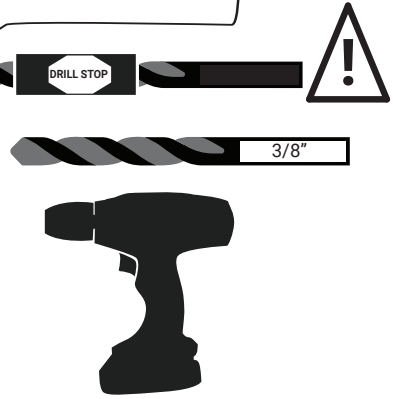
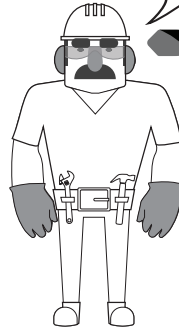

1/4" - 20 Zinc Plated Insert Nut

6.

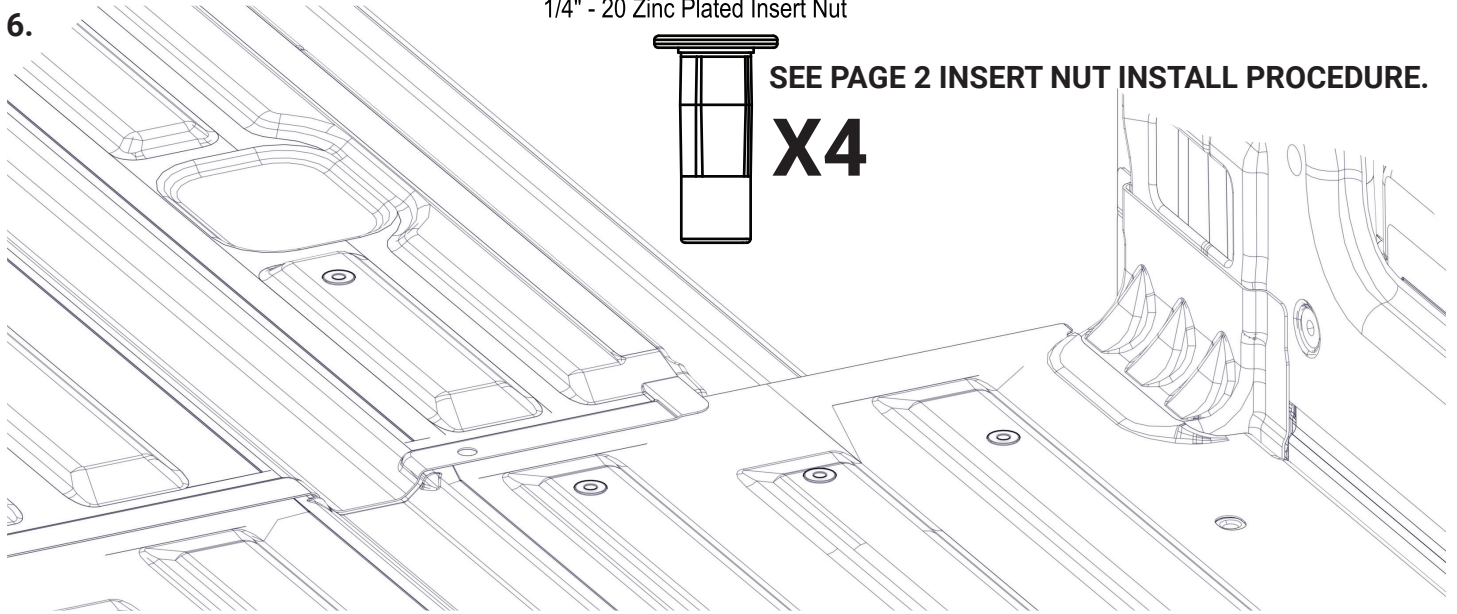

SEE PAGE 2 INSERT NUT INSTALL PROCEDURE.

**X4**

7.

Aluminum Spacer 3/8" Thick x 1" OD x 7/16" ID

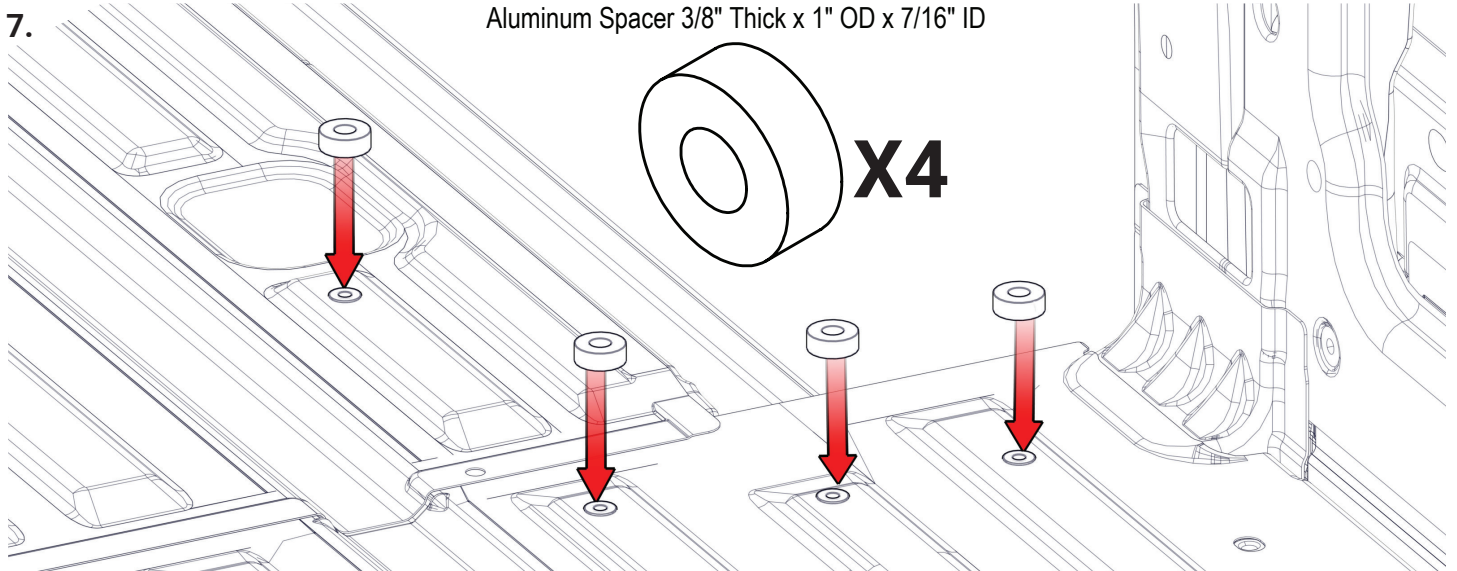

**X4**

8.

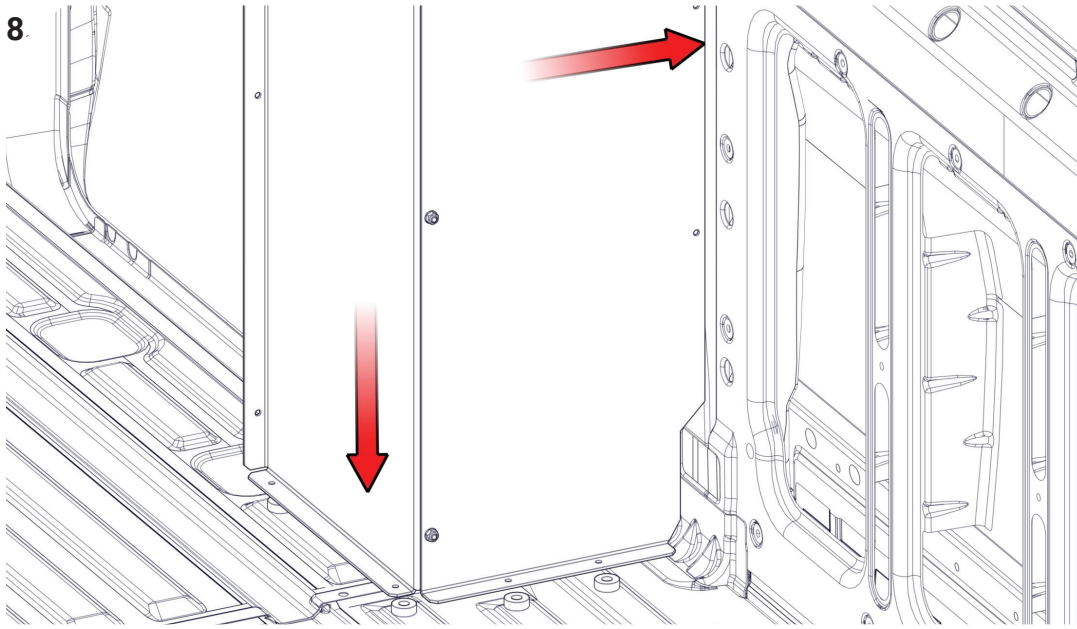

1/4" x 1 1/2" Zinc plated Hex Bolt



1/4" Plated Zinc Lock Washer



**X2**

1/4" Plated Zinc Washer

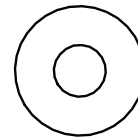

**X2**

**X2**

**TEMPORARILY FASTEN THE PARTITION ASSEMBLY TO MARK THE INSERT NUT DRILL LOCATIONS IN THE C-PILLAR SURFACE.**

9.

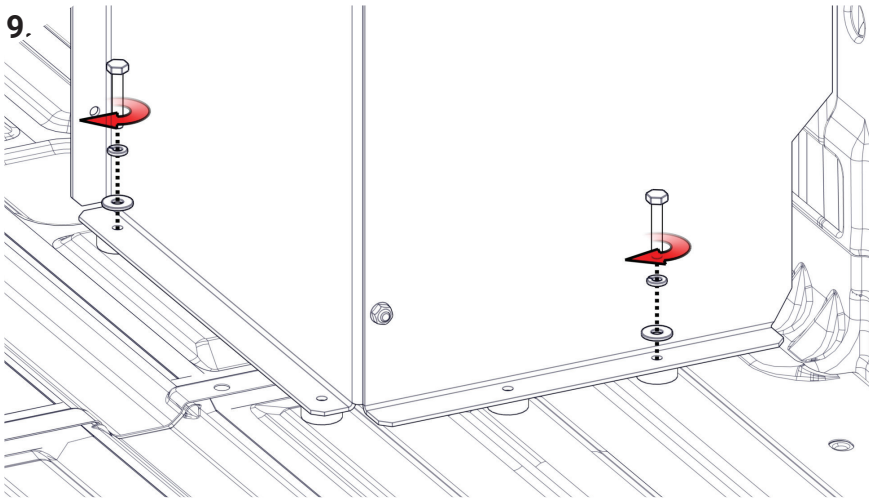

10.

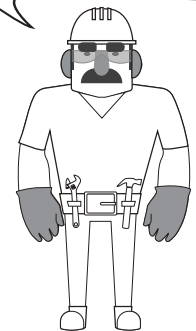
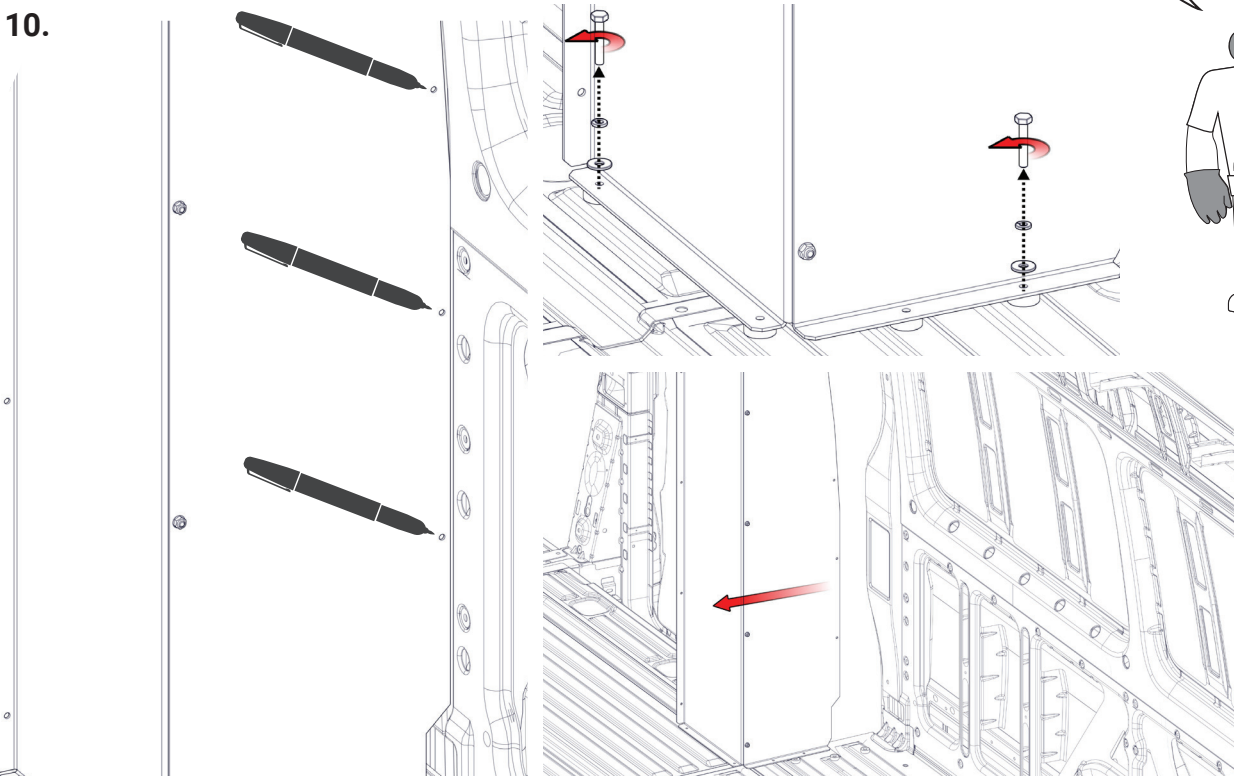

11.

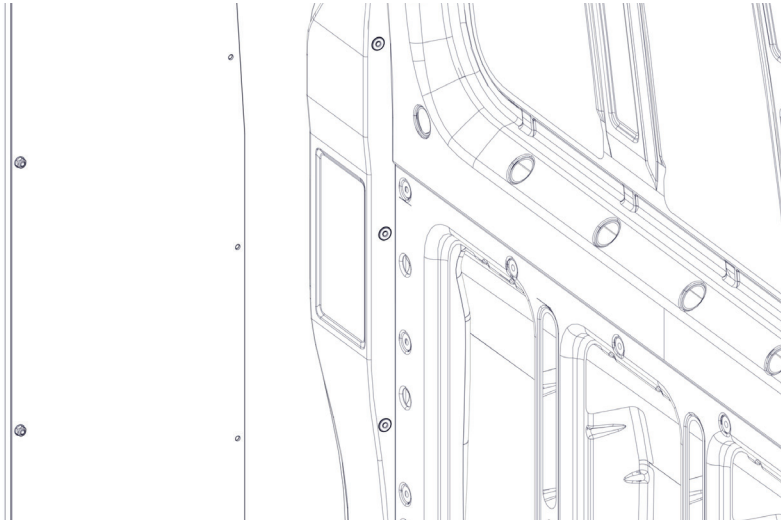

**DRILL MARKED LOCATIONS WITH  
A 3/8" DRILL BIT AND INSTALL  
INSERT NUTS.**

1/4" - 20 Zinc Plated Insert Nut

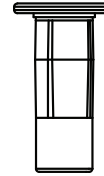

**X3**

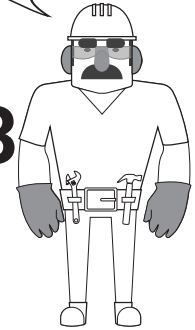

12.

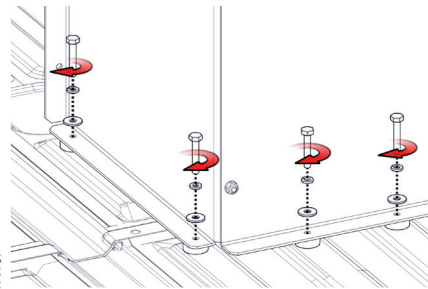
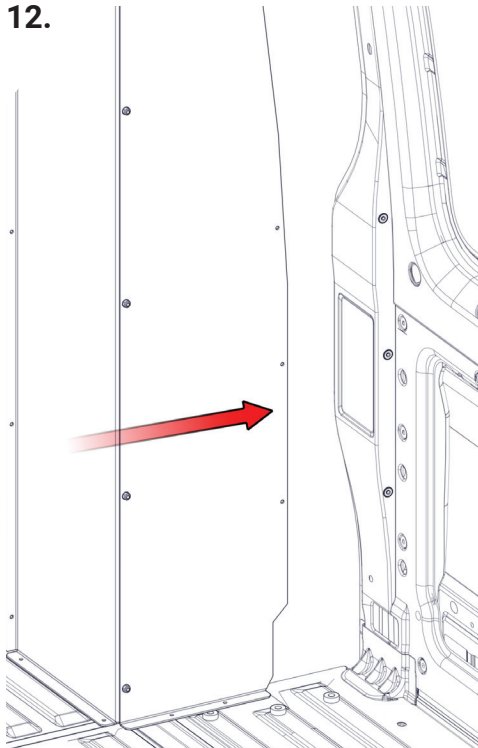

1/4" Plated Zinc Lock Washer



1/4" x 1 1/2" Zinc plated Hex Bolt

**FLOOR ONLY**

**X4**

1/4" Plated Zinc Washer



**X7**

1/4" x 1 1/4" Zinc Plated Full Thread Hex Bolt

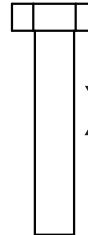

**X3**

13.

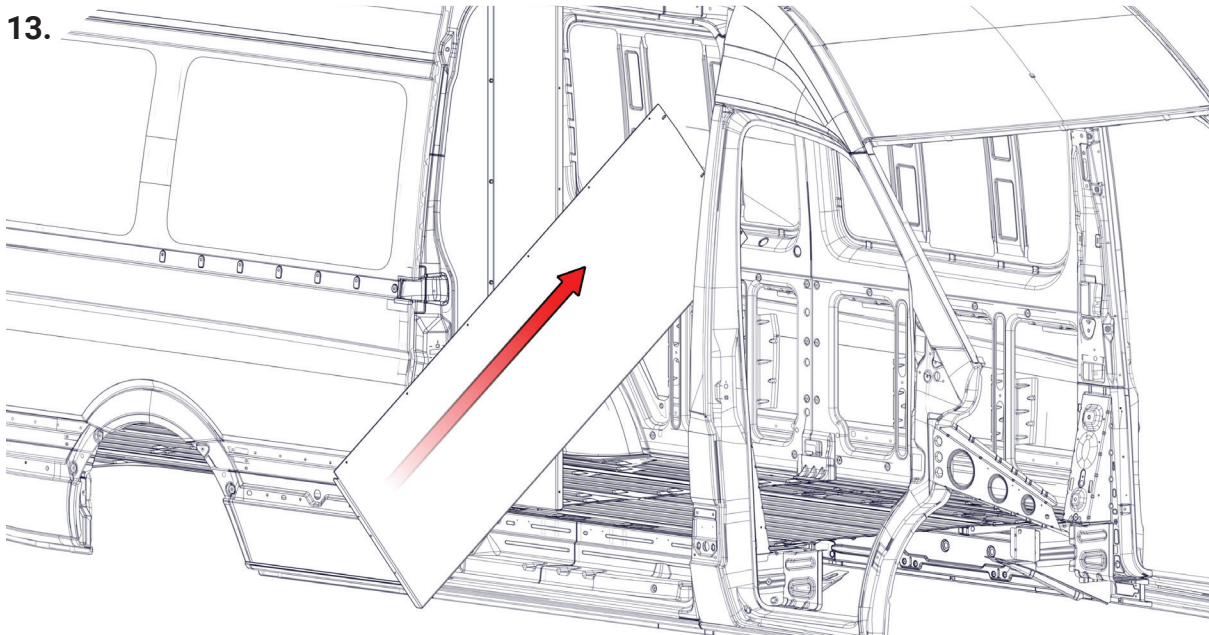

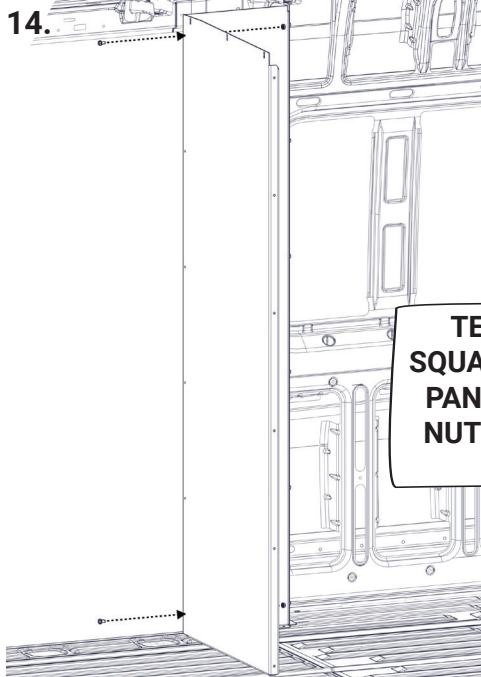

14.

1/4" Zinc Plated Flange Nut



1/4" X 1/2" Zinc Plated Flange Hex Bolt



TEMPORALLY FASTEN AND SQUARE THE PARTITION CENTER PANEL AND MARK THE INSERT NUT DRILL LOCATIONS ON THE FLOOR.

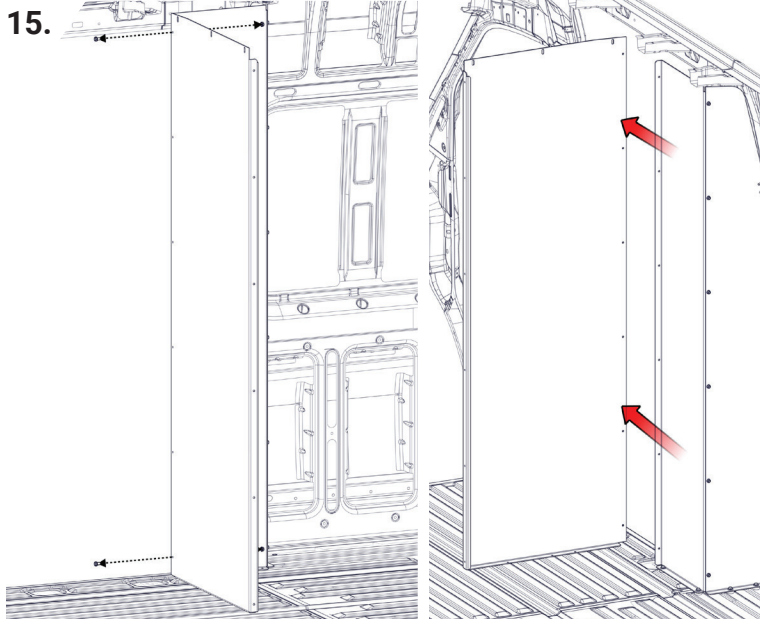
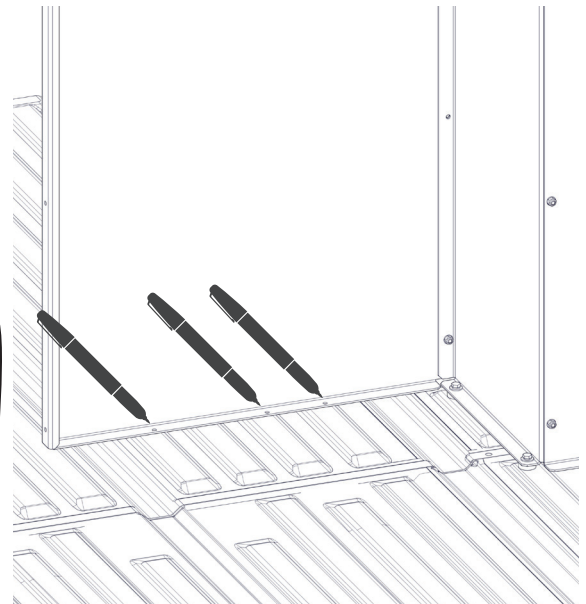
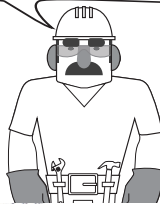

15.

DRILL MARKED LOCATIONS WITH A 3/8" DRILL BIT AND INSTALL INSERT NUTS.

1/4" - 20 Zinc Plated Insert Nut

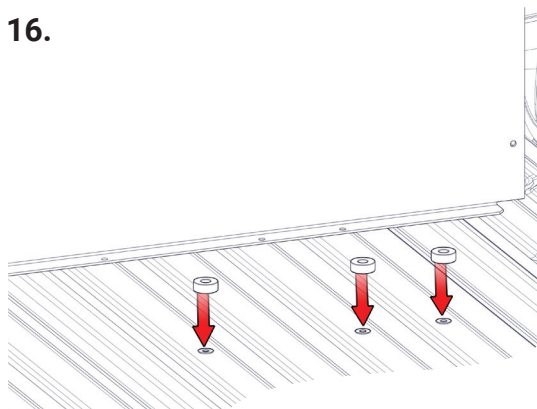
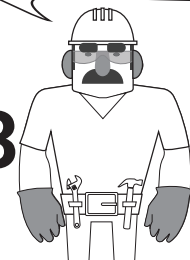
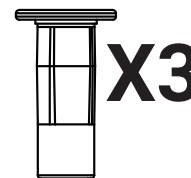

16.

Aluminum Spacer 3/8" Thick x 1" OD x 7/16" ID

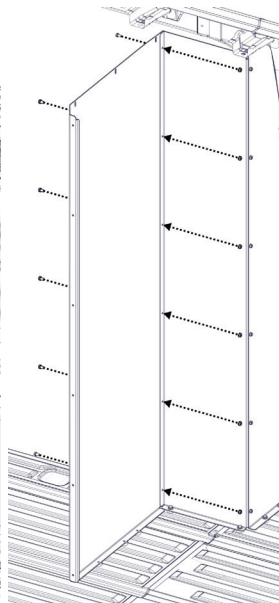
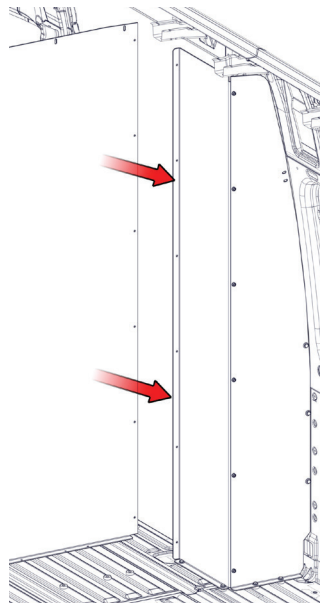

1/4" Zinc Plated Flange Nut



1/4" X 1/2" Zinc Plated Flange Hex Bolt





17.

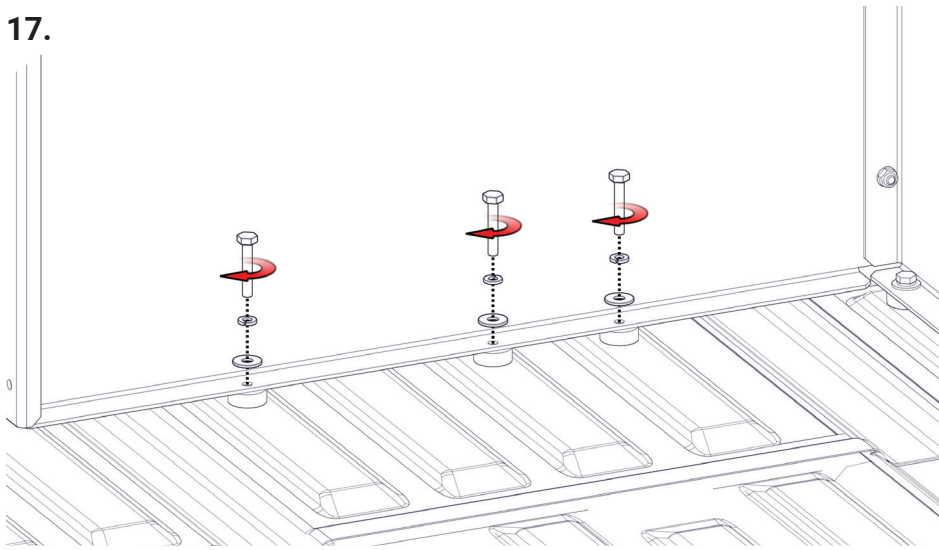

- 1/4" x 1 1/2" Zinc plated Hex Bolt
- 1/4" Plated Zinc Lock Washer X3
- 1/4" Plated Zinc Washer X3

18.

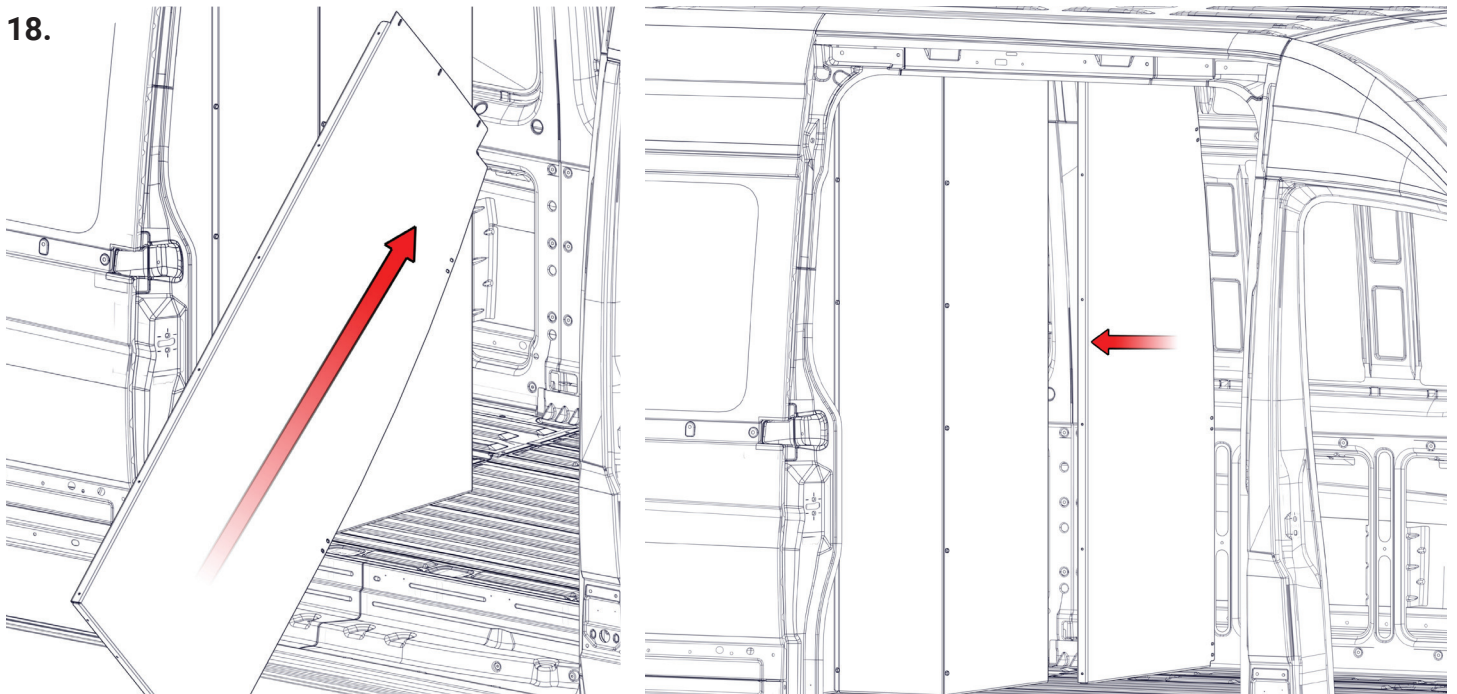

19.

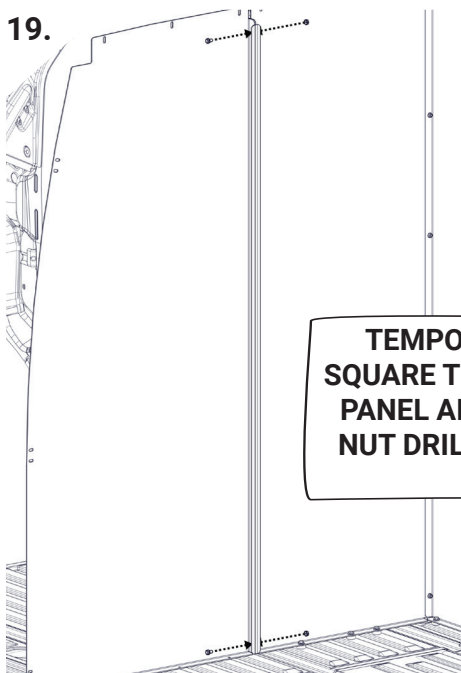

- 1/4" Zinc Plated Flange Nut X2
- 1/4" X 1/2" Zinc Plated Flange Hex Bolt X2

**TEMPORALLY FASTEN AND SQUARE THE PARTITION CENTER PANEL AND MARK THE INSERT NUT DRILL LOCATIONS ON THE FLOOR.**

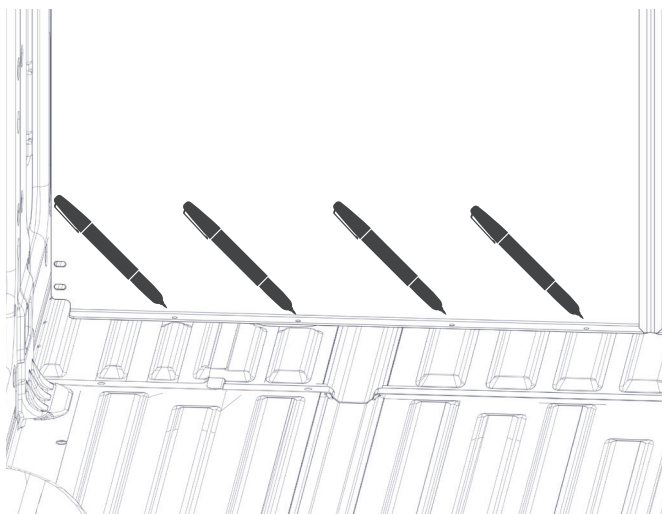

20.

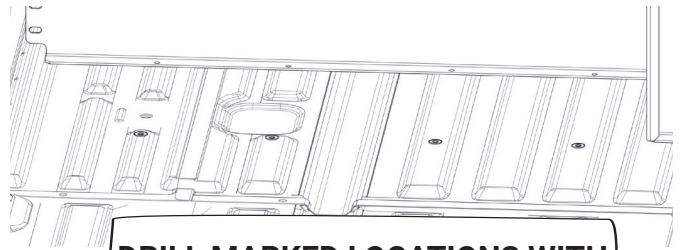
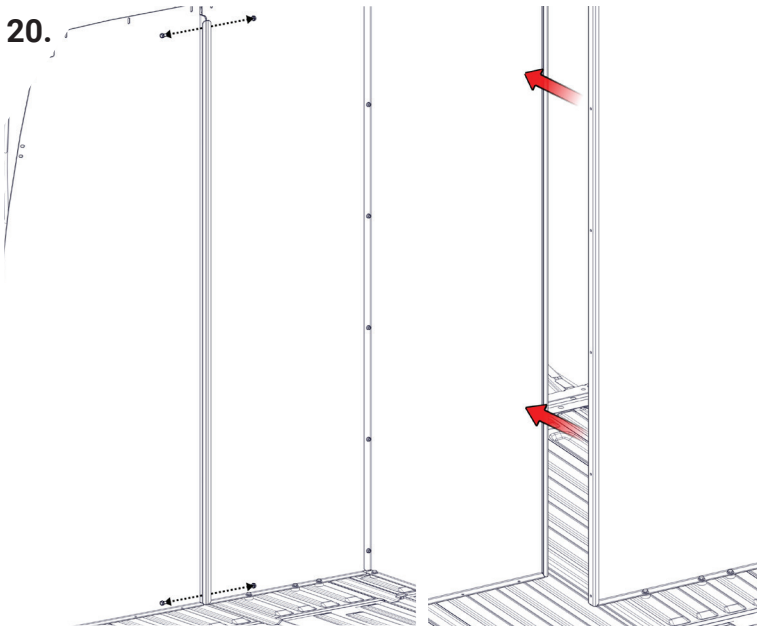

**DRILL MARKED LOCATIONS WITH A 3/8" DRILL BIT AND INSTALL INSERT NUTS.**

1/4" - 20 Zinc Plated Insert Nut

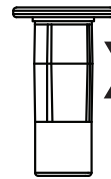

**X3**

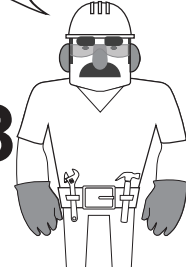

1/4" Zinc Plated Flange Nut



**X6**

1/4" X 1/2" Zinc Plated Flange Hex Bolt



**X6**

21.

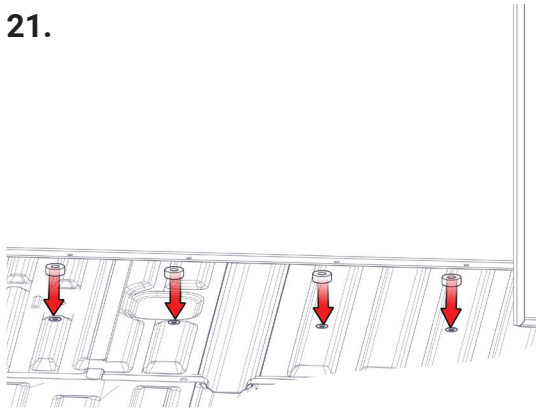

Aluminum Spacer 3/8" Thick x 1" OD x 7/16" ID

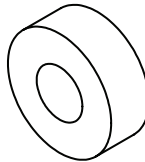

**X3**

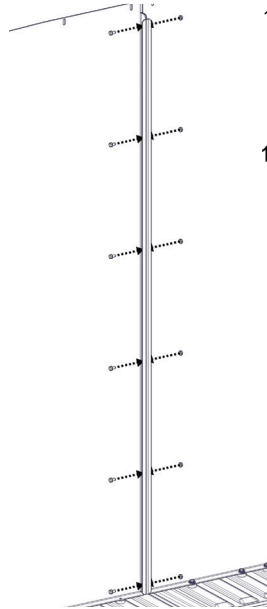
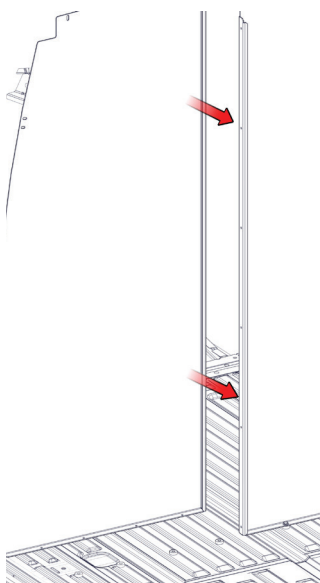

22.

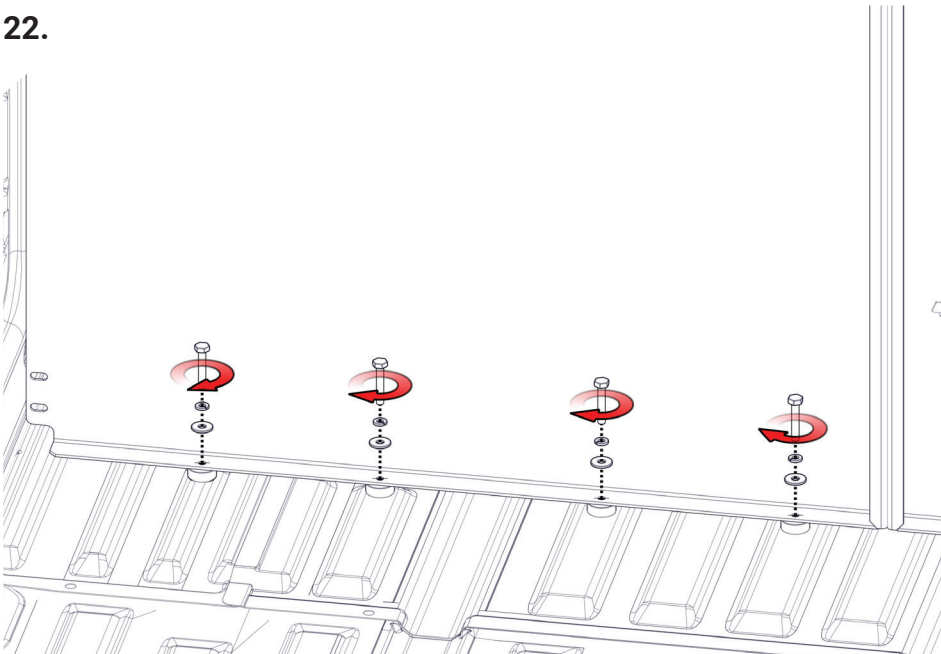

1/4" x 1 1/2" Zinc plated Hex Bolt

1/4" Plated Zinc Lock Washer



**X4**

1/4" Plated Zinc Washer

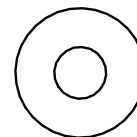

**X4**



**X4**

23.

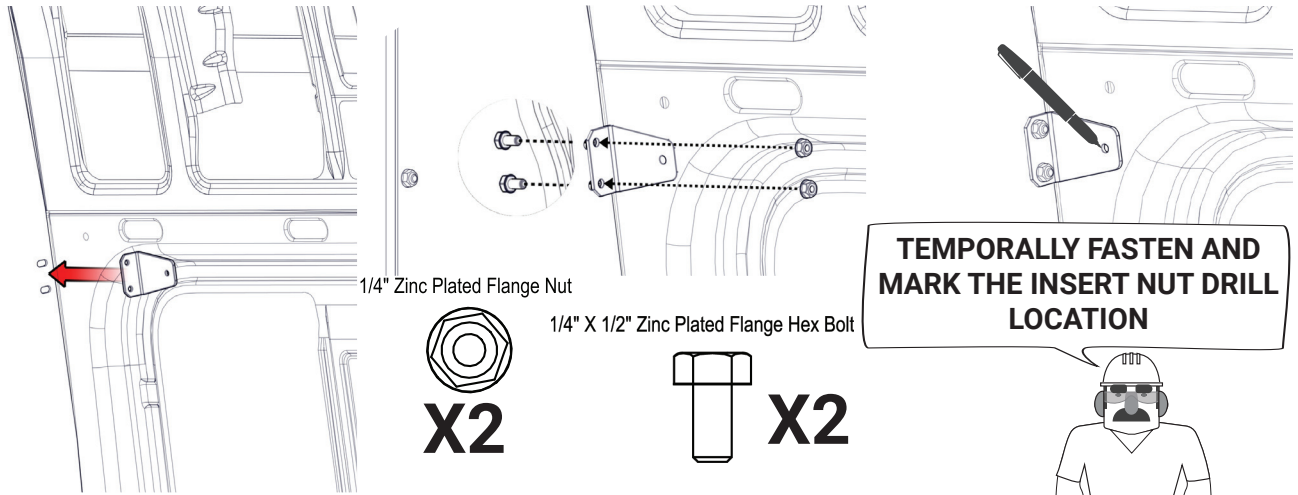

24.



25.

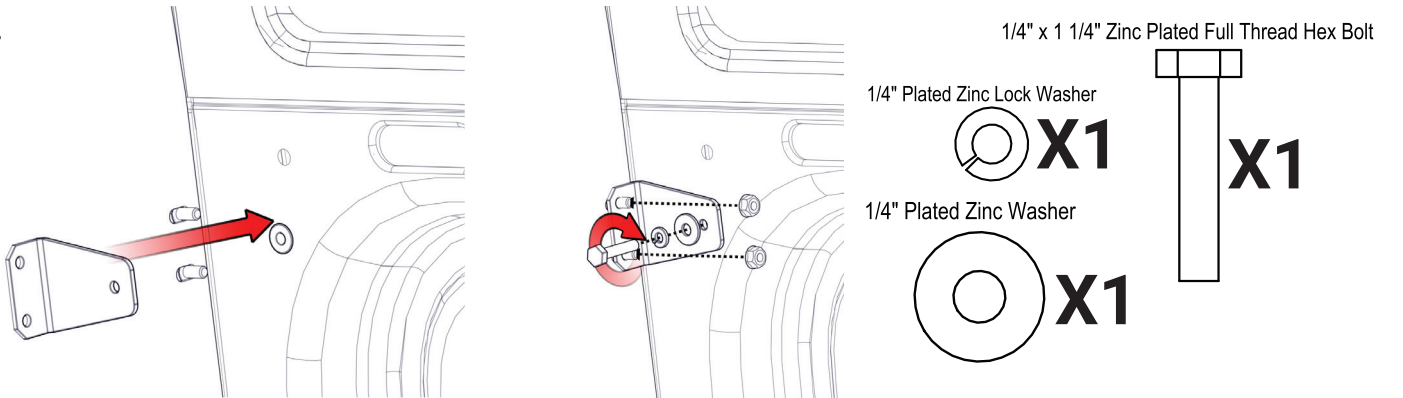

26.

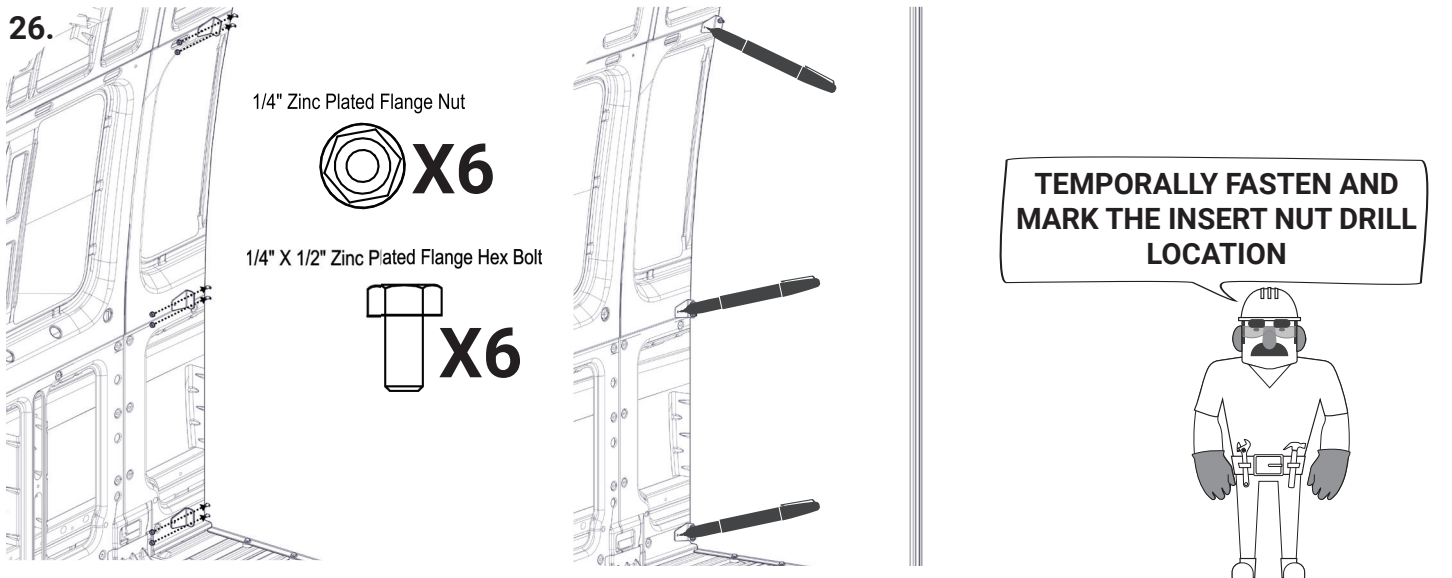

26.

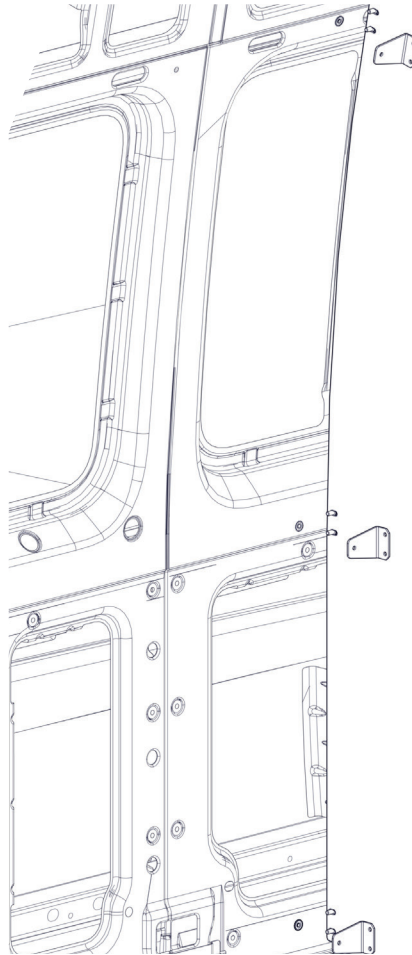
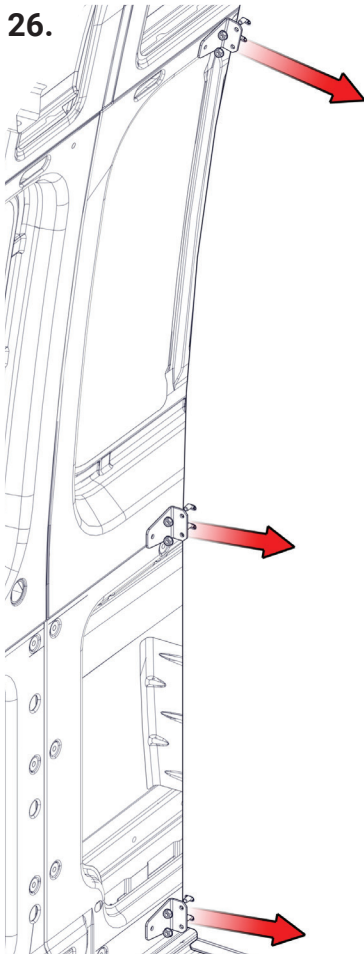

**DRILL MARKED LOCATIONS WITH  
A 3/8" DRILL BIT AND INSTALL  
INSERT NUTS.**

1/4" - 20 Zinc Plated Insert Nut

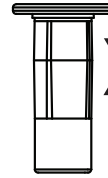

**X3**

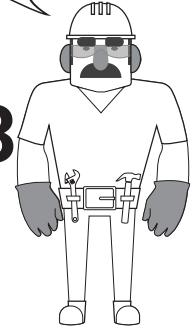

27.

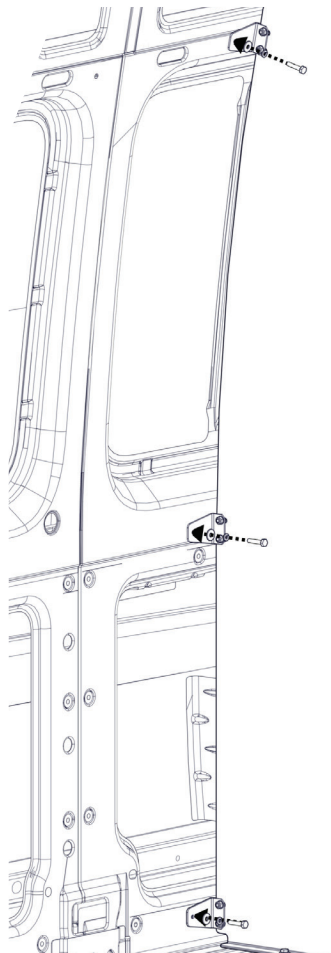
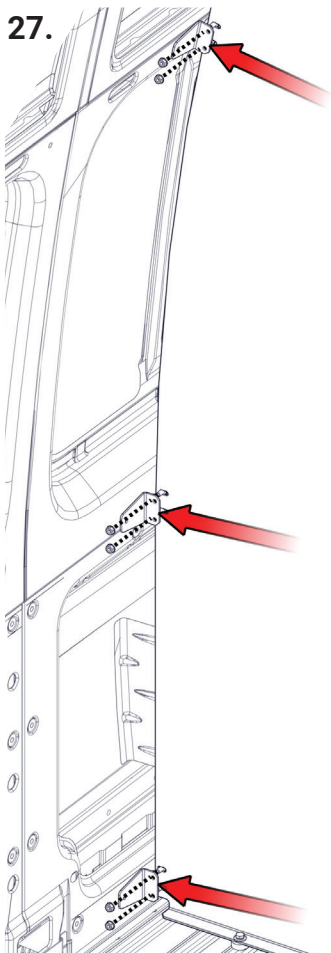

1/4" x 1 1/4" Zinc Plated Full Thread Hex Bolt

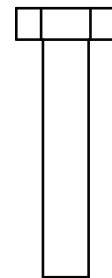

**X3**

1/4" Plated Zinc Washer

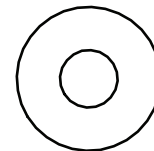

**X3**

1/4" Plated Zinc Lock Washer



**X3**

28.

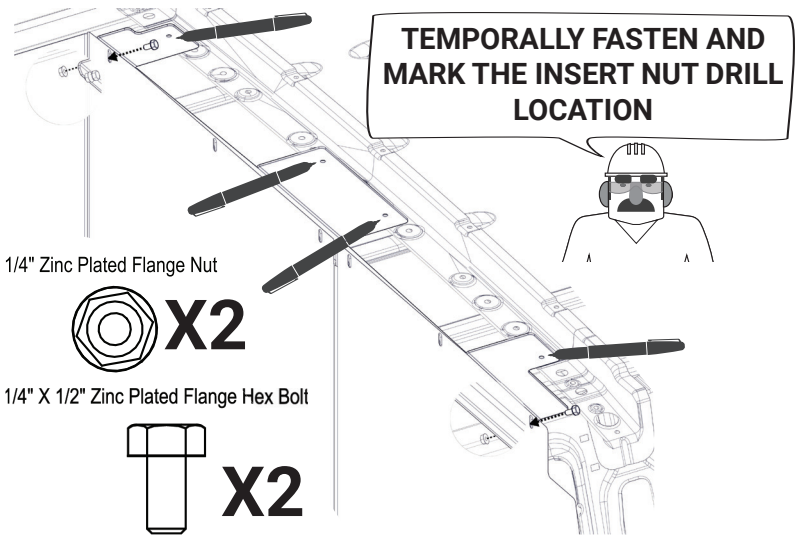
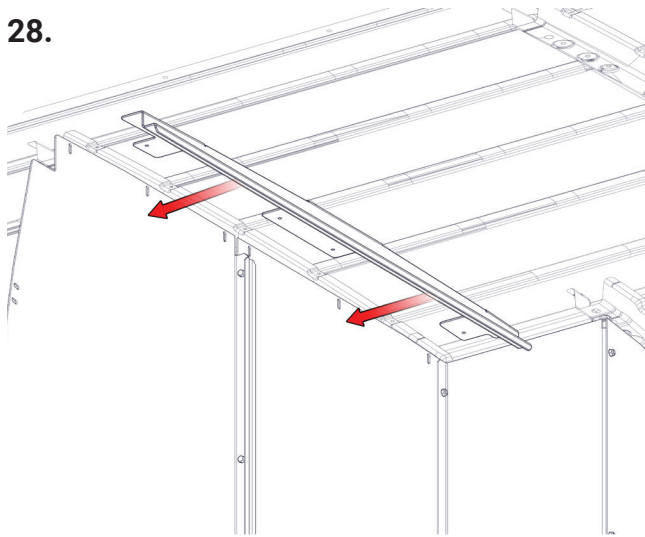

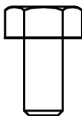
1/4" Zinc Plated Flange Nut  
 **X2**  
 1/4" X 1/2" Zinc Plated Flange Hex Bolt  
 **X2**

29.

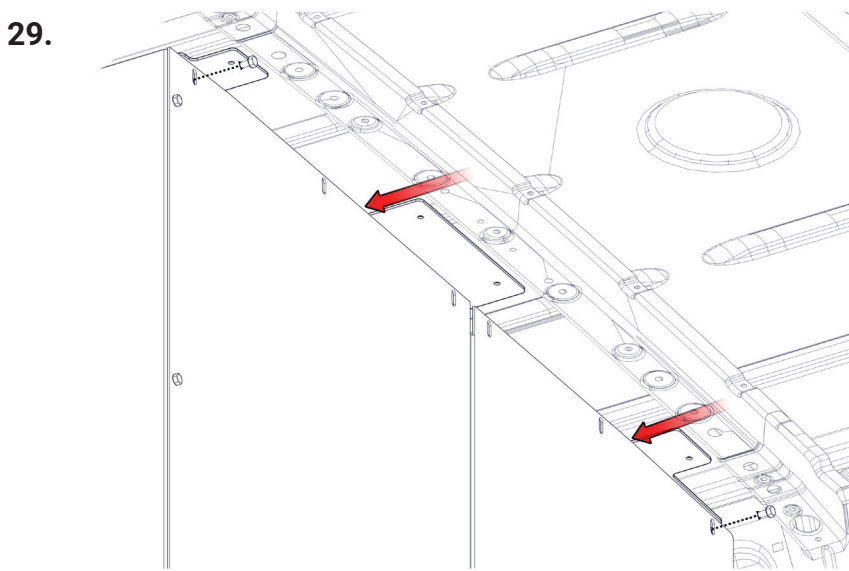

**DRILL MARKED LOCATIONS WITH A 3/8" DRILL BIT AND INSTALL INSERT NUTS.**

1/4" - 20 Zinc Plated Insert Nut



**X4**

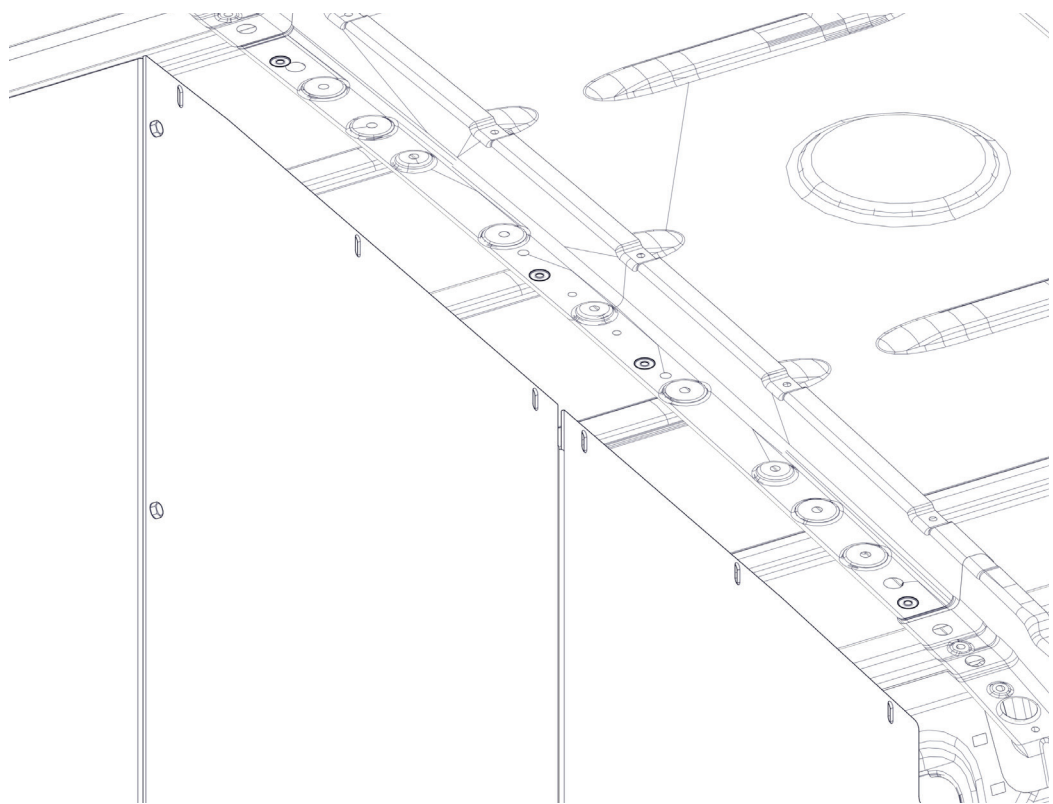
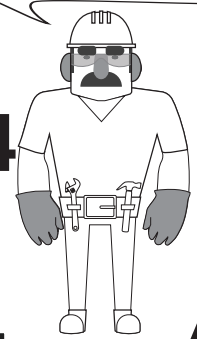

30.

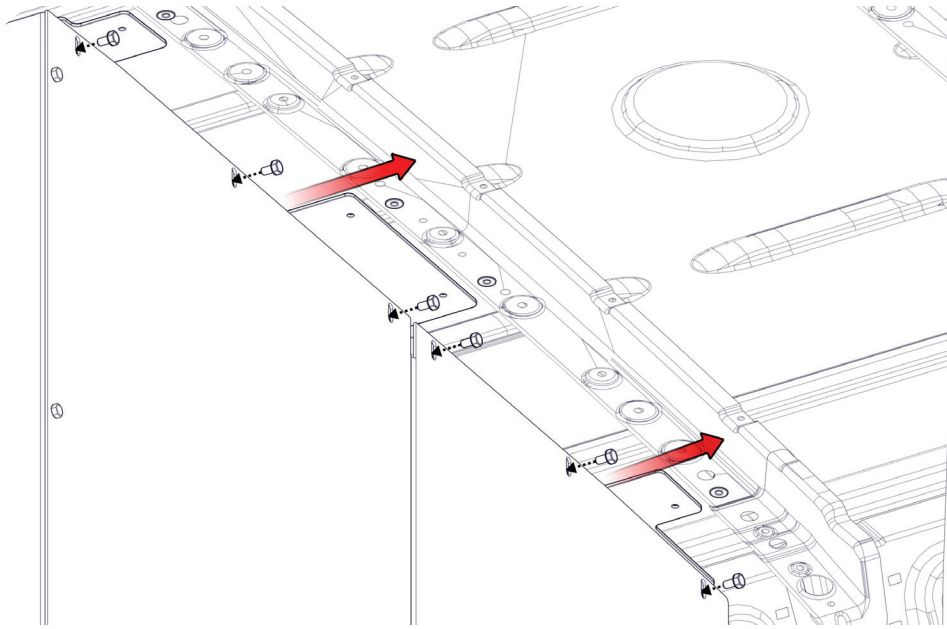

1/4" Zinc Plated Flange Nut



1/4" X 1/2" Zinc Plated Flange Hex Bolt



31.

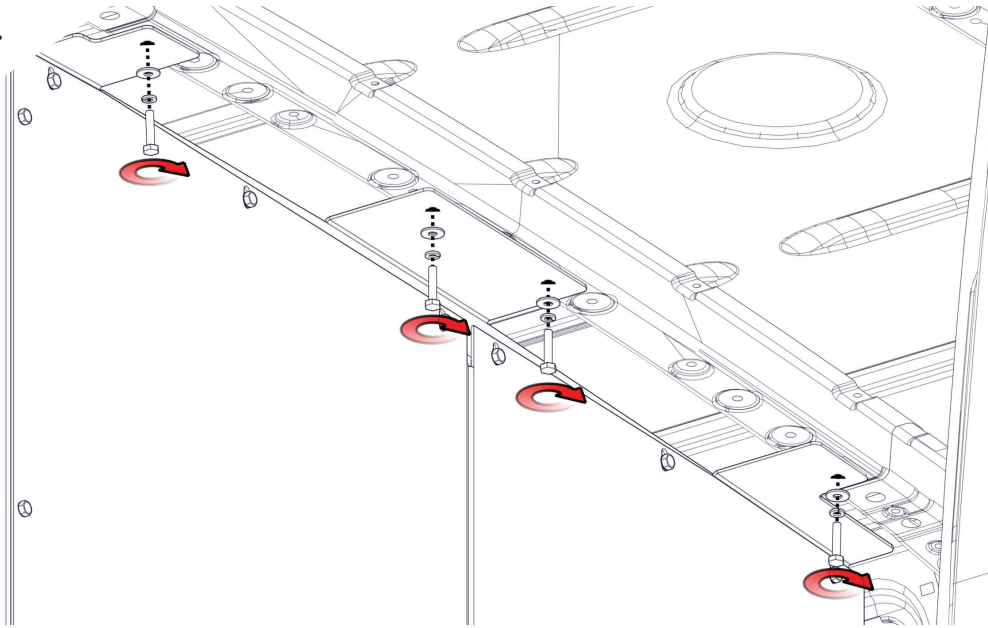

1/4" x 1 1/4" Zinc Plated Full Thread Hex Bolt

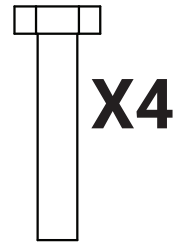

1/4" Plated Zinc Washer



1/4" Plated Zinc Lock Washer

